

Upgrade Innovation to Master Innovation



Loving music

User manual



Master Innovation Black

Picture with:
Clearaudio tonearm „Universal“
and clearaudio cartridge
„Goldfinger Statement“.



Master Innovation Wood

Picture with:
Clearaudio tonearm „TT1 MI“
and Clearaudio cartridge
„Goldfinger Statement“.

User manual

Dear **Clearaudio** customer,

Congratulations to your choice to upgrade your *Innovation* to a *Master Innovation* turntable, a world class turntable, handmade in Germany by **Clearaudio electronic GmbH**.

Like the model *Innovation* the *Master Innovation* has a resonance minimizing chassis construction in a sandwich combination with the innovative motor unit (low noise level and high turning moments), which guarantees total isolation of resonances from the turntable chassis, providing the best music reproduction and authentic High End imaging.

The **Clearaudio** patented CMB-Bearing-Technology, an inverted bearing with jewelled and polished ceramic bearing shaft and a bronzed liner, provides frictionless analogue enjoyment.

This user manual described the reconstruction from the turntable *Innovation* to the turntable *Master Innovation*.

For more information regarding the *Master Innovation* you will get a separate user manual.

We wish you a lot of musical enjoyments with your new **Clearaudio** *Master Innovation* turntable.

Clearaudio electronic GmbH

This section must be read before any connection is made to the mains supply.

WARNING

Do not expose your turntable to rain or humidity.

Do not handle mains leads with wet hands.

No naked flame sources, such as lighted candles, should be placed on the equipment.

CE-MARKING



The **Clearaudio** *Master Innovation* meets the regulations concerning electromagnetic disturbance (EMC) and low-voltage appliances.

EQUIPMENT MAINS POWER SETTING

Your Clearaudio product has been prepared to comply with the household power and safety requirements that exist in your area. This product can be connected to 230 V or 110 V AC (50 Hz and 60 Hz).

COPYRIGHT

Recording and reproduction of any audio material may require the consent of the creator.

Please note relevant information given in the following:

- Copyright Act 1956
- Dramatic and Musical Performers Act 1958
- Performers Protection Acts 1963 and 1972
- Any relevant recent legal regulations.



Contents

1. Packing overview	4
2. List of components	5
3. Reconstruction Innovation to Master Innovation	6 - 16
4. Fine adjustment of the motor	16
5. Special notes	17
6. Technical data	18
Warranty – information	19

1. Packing overview

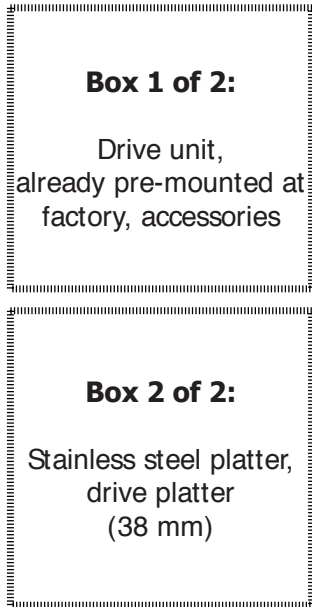
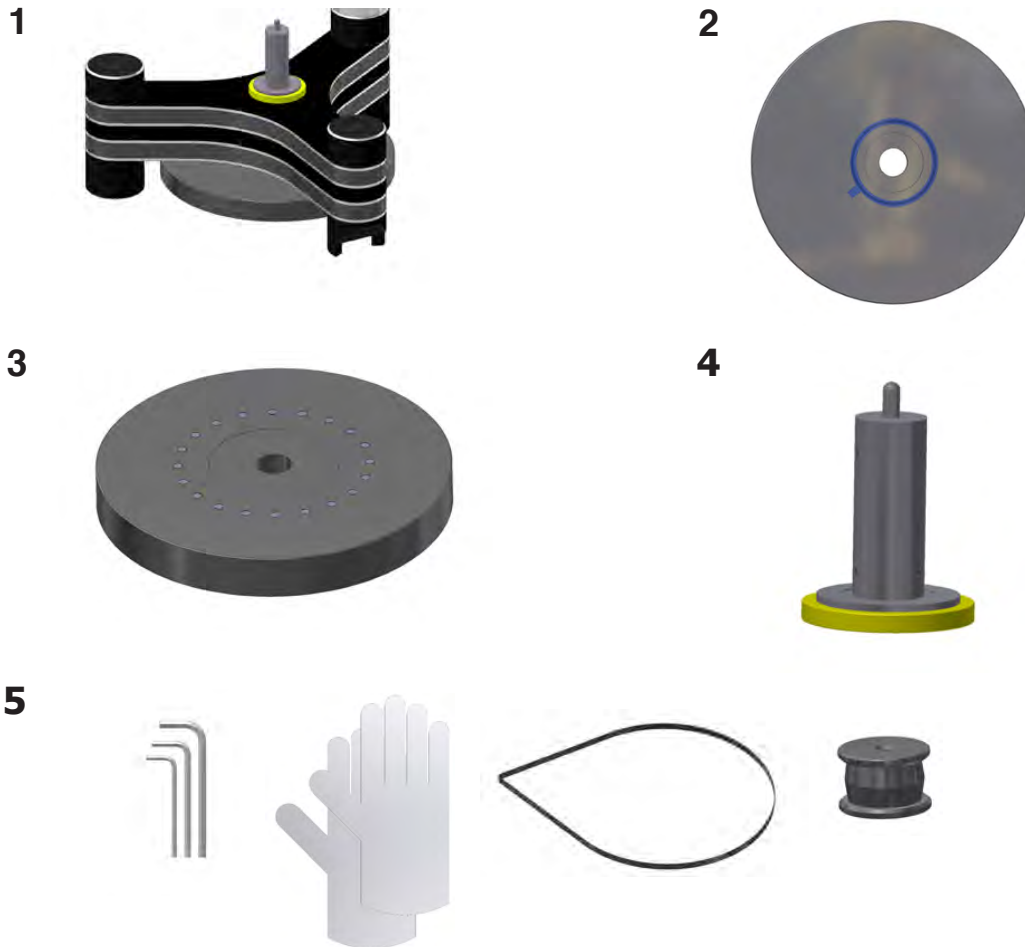

Fig. 1: Packing overview

2. List of components

Clearaudio's special secure packaging for your *Master Innovation* turntable ensures safe transportation. Please keep this original packaging, in case you need to transport or ship the turntable at any point in the future.

Clearaudio *Master Innovation* components list:



Pic. 2: List of components

1.	First drive unit, pre-mounted (Box 1 of 2)	4.	Drive bearing
2.	Stainless steel sub-platter (Box 2 of 2)	5.	Accessoires: Pulley, white gloves, 2x drive belts, hex wrench (# 8), bearing oil, user manual, QQQ-Card, warranty card
3.	Platter with magnets (28mm) (Box 2 of 2)		

3. Reconstruction Innovation to Master Innovation

The reconstruction of the turntable *Innovation* to *Master Innovation* is easy as most parts of the turntable chassis are already pre-assembled and has been tested at the factory.

Please use the enclosed white gloves in order to avoid scratches or unwanted fingerprints on the turntable parts or platters.

After the reconstruction the *Master Innovation* turntable requires a space for setup of at least (in inch): 18.9 x 19.3.

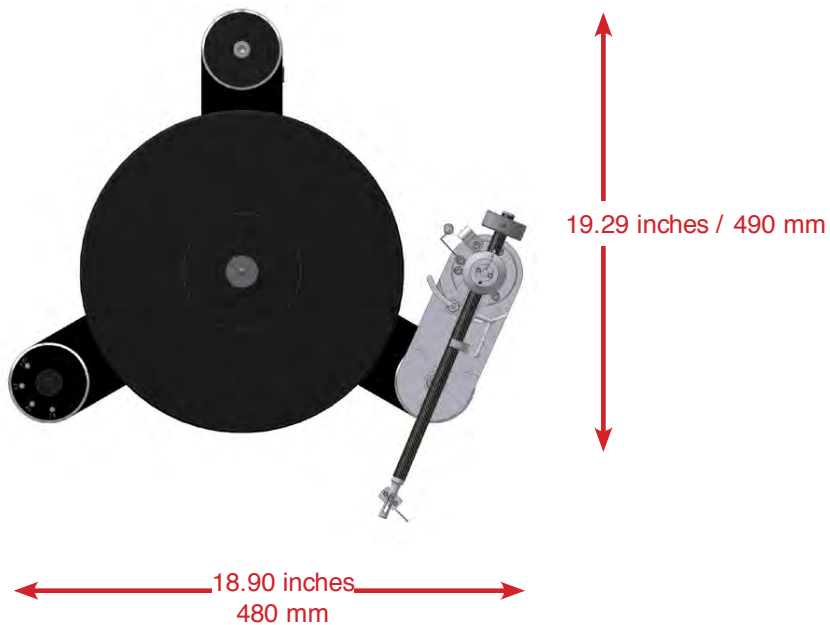

Pic. 3: Required setup space (with **Clearaudio** tonearm *Unify*)

User manual

Before you can start to reconstruct the *Innovation* turntable to the *Master Innovation* please pay attention that **all bases of the *Innovation* turntable have the height of 40 mm!** If one of your bases has not the height of 40 mm, please contact the dealer, where you have purchased your *Innovation* turntable.

1.)

Take off the tonearm base and the blind screw on the other base at your *Innovation* turntable (as shown in Pic. 4).



Pic. 4: *Innovation* turntable backside

2.)

In the next step take off carefully the drive platter of your *Innovation*. Please keep all platters with you, as you need the platters again for the upgrade to the *Master Innovation*.

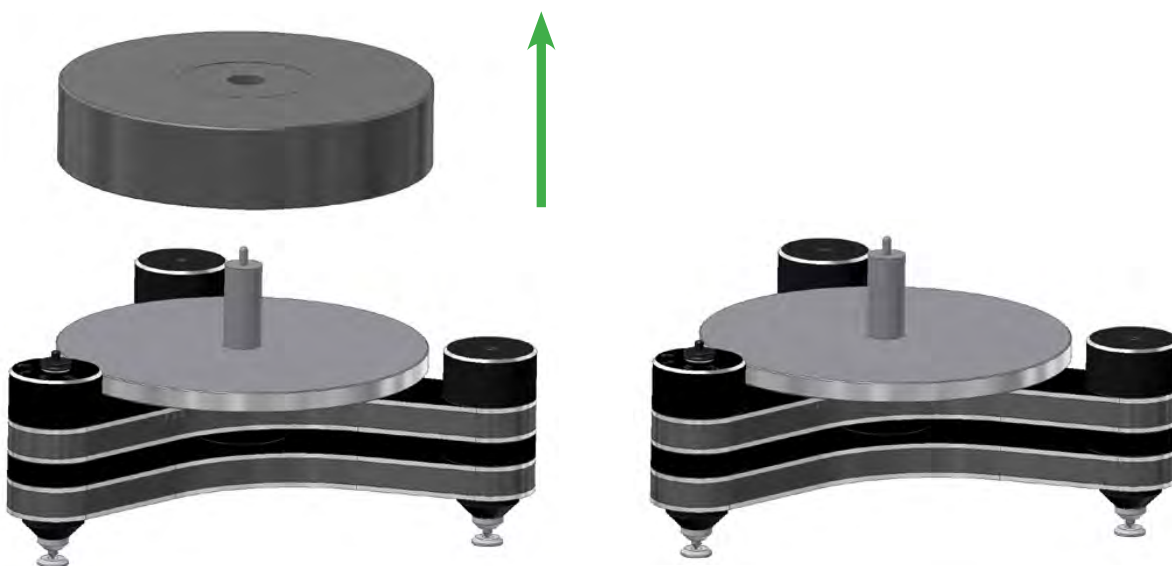

Pic. 5: Taking off the drive platter

3.)

Now remove carefully the stainless steel platter with the mounting clip (accessory of *Innovation* turntable).

Avoid major side forces to avoid any damages to the ceramic bearing!

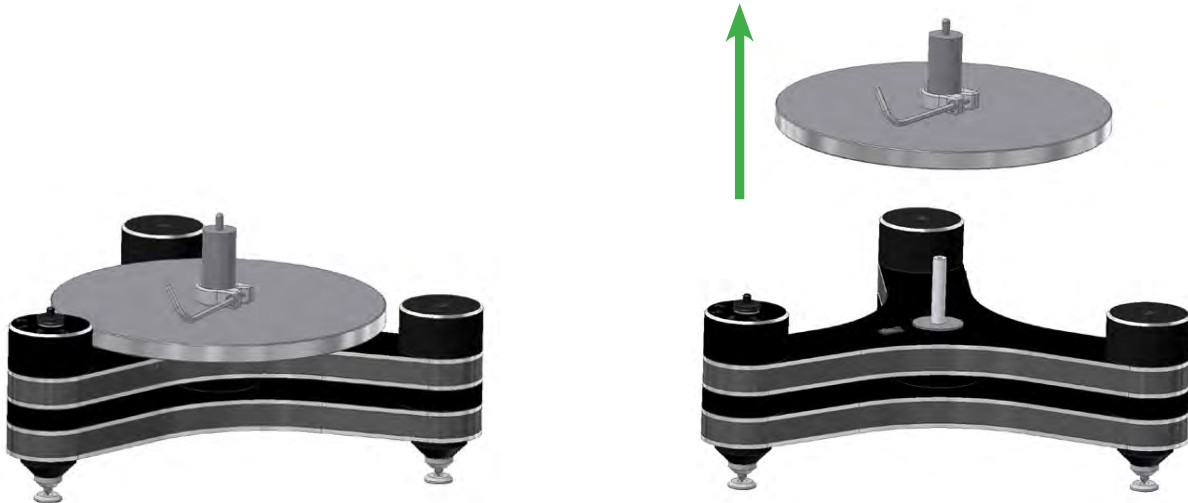

Fig. 6: Taking off the stainless steel platter

4.)

Next please remove the bearing of your *Innovation*. For that unscrew carefully the screw on the lower side of the turntable and pull the bearing out of the chassis.

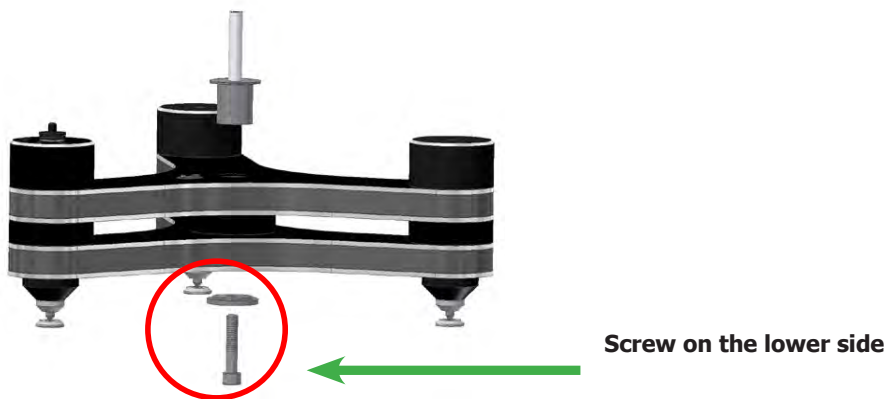

Fig. 7: Removing the bearing

User manual

5.)

Take out the delivered drive bearing for the *Master Innovation*.

Please remove carefully any protective security tape from the bearing.

Now you can put the new bearing into the chassis (see pic. 6) and arm the bearing with the delivered screw on the lower side of the turntable.

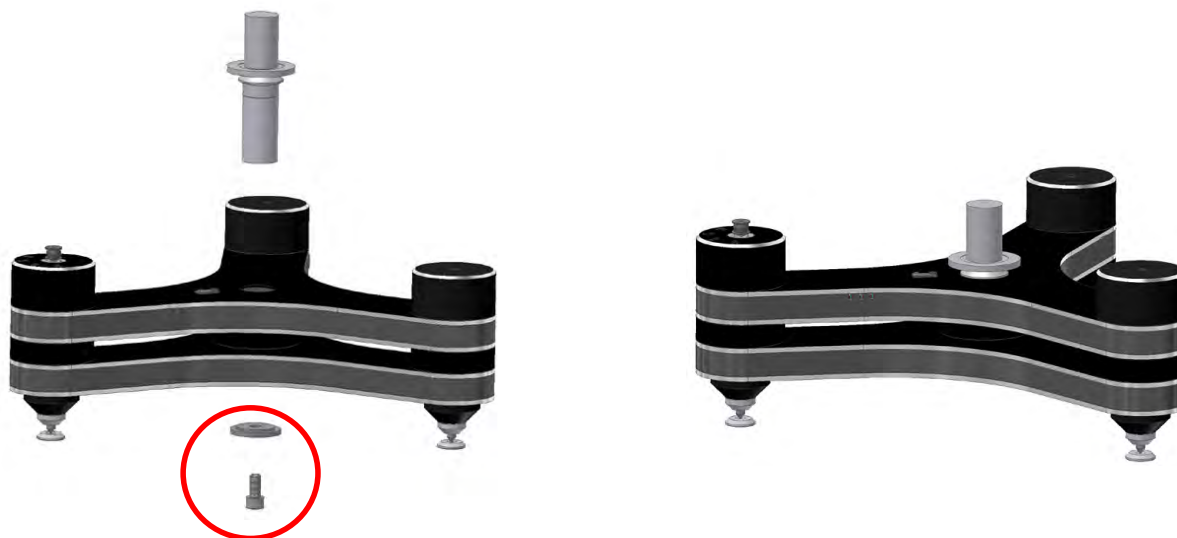

Pic. 8: Setup of the drive bearing

6.)

Now please exchange the pulley of the *Innovation* turntable with the delivered pulley.

Pulley *Innovation*

Pic. 9: Exchange of the pulleys

Please pay attention that the exchanged *Master Innovation* pulley is flush mounted with the axis of the motor.

Pulley for *Master Innovation*



Pic. 10: Setup of the *Master Innovation* pulley

Now the upgrade from the *Innovation* to the *Master Innovation* is completed and you can switch over to the setup of the *Master Innovation*.

In the user manual for the *Master Innovation* you will find the packing list, packing overview and of course the whole description for the setup of the *Master Innovation*.

To make it easier for you, you can also go ahead with the following description:

7.)

In the next step remove carefully the lamination of the sensor on the upper surface of the turntable chassis.

Please remove the lamination extreme carefully and avoid any soiling and scratches.

Take the stainless steel sub-platter again carefully with both hands and put it onto the bearing. The lower side must show to the bearing. Through a lightly (!!) up and down movement the platter will slip onto the bearing upper part (Pic. 11 and 12).

Please remove the lamination extreme carefully and avoid any soiling and scratches.



Pic. 11: Setup of the sub platter



Pic. 12: Setup of the sub platter

8.)

Take the drive platter with both hands carefully out of the box and remove the protection sheet. Please pay attention that the magnets on the upper surface of the drive platter must be faced upwards.

Magnets (face upwards)**Fig. 13:** Setup of the drive platter**9.)**

Put one of the delivered drive belts around the drive platter and the pulley. Please pay attention that the drive belt is not twisted.

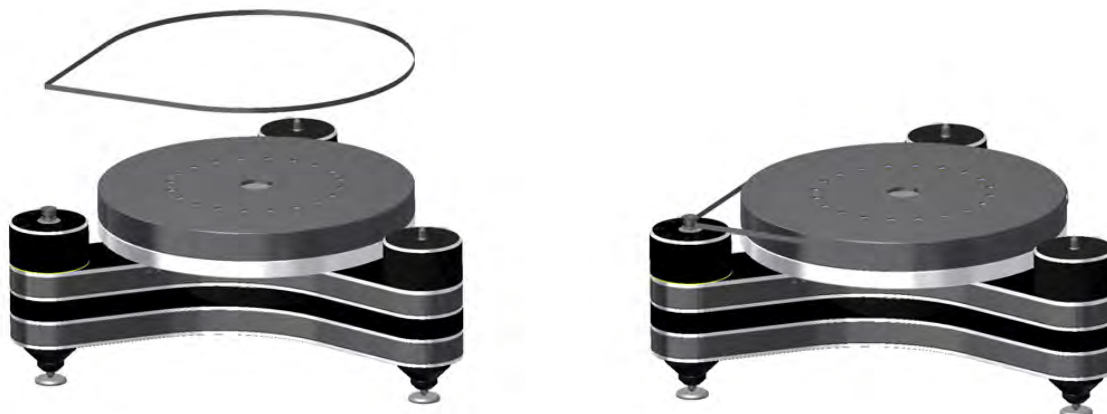
**Fig. 12:** Setup of the drive belt

10.)

Now take carefully the turntable unit out of the box 2 und set it onto the drive unit as shown in the picture below (pic.13) Please pay attention that the **protection sheet between both units still remain to** avoid any damages!

Please pay attention that **all center pins must be set very carefully into all threaded holes.**

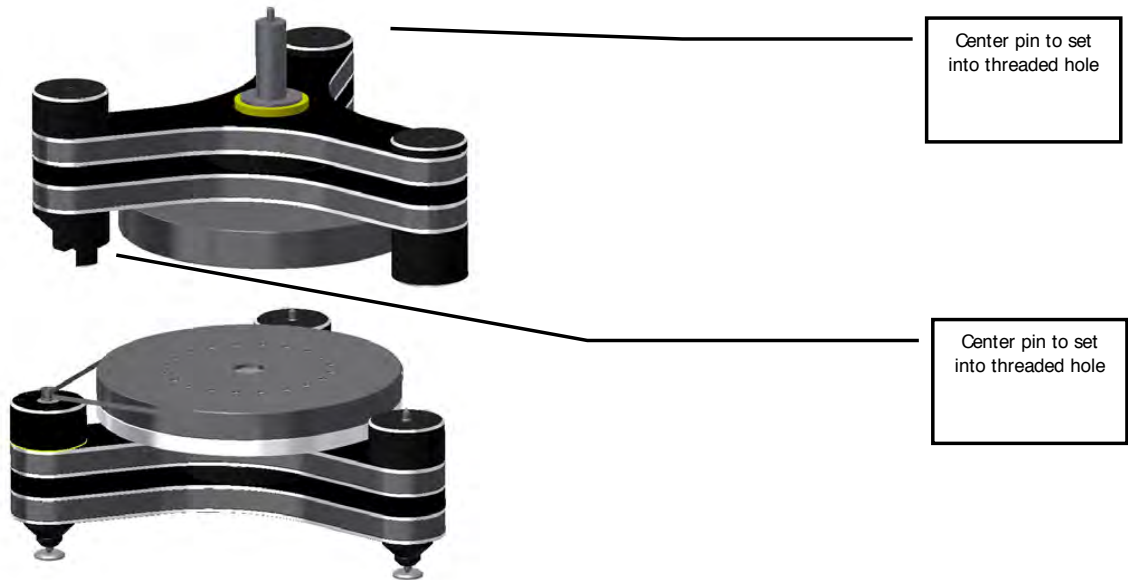

Pic. 13: Setup of the turntable unit

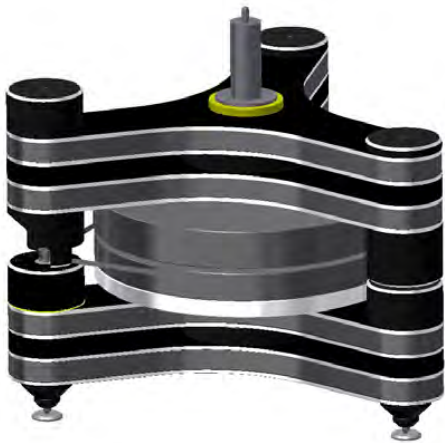

Pic. 14: Finished setup of the turntable unit

11.)

Take the stainless steel sub-platter out of the box 3 and remove only the protection sheet, but keep the protection film of the upper side of the sub-platter.

Put the sub-platter very carefully onto the upper part of the bearing (pic. 15a)

Now take the main platter out of the box and set it up onto the upper part of the bearing.

The recess for the label must be faced upwards. Now you can carefully remove the protection film (pic. 15b). To avoid any damages on your bearing, the Delrin platter should have room temperature before the setup begin (approx. 20 ° Celsius).

Avoid major side forces to avoid any damages to the ceramic bearing!

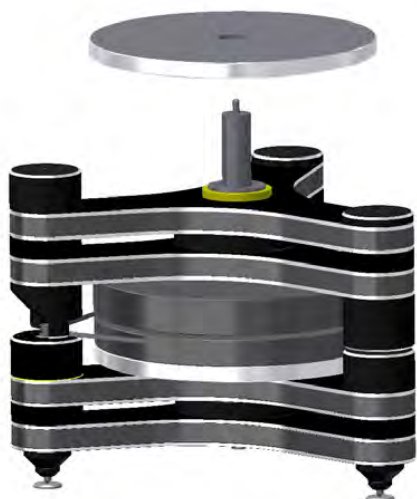

Pic. 15a: Setup of the stainless steel subplatter

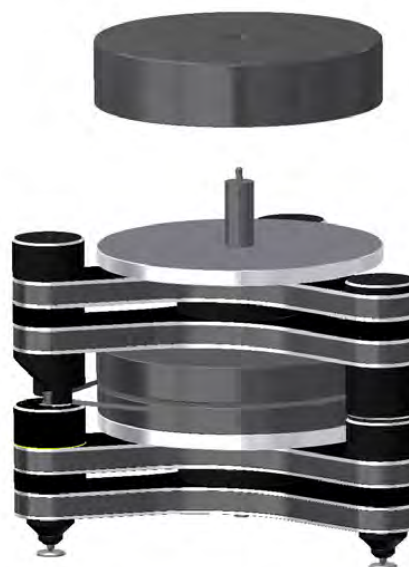

Pic. 15b: Setup of the main platter



Pic. 16: Finished setup

User manual

You will find suitable adjustment equipment under www.clearaudio.de or www.analogshop.de.

12.)

To install the tonearm, please follow the user manual of the respective manufacturer.

If you purchased your **Clearaudio Innovation** turntable as a package with tonearm and cartridge, you will find a *Smart Level Gauge* in your accessory, which will help you to adjust the tracking force of the cartridge:

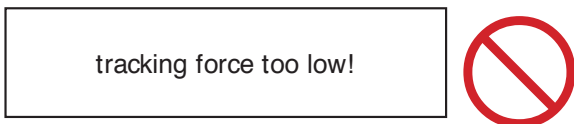
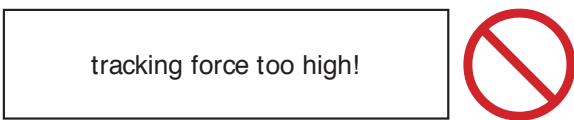
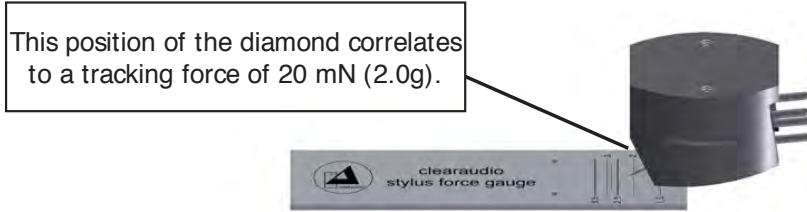

Pic. 17: Using the *Smart Stylus Gauge*

13.)

To mount and adjust a cartridge, please follow the user manual of the respective manufacturer.

14.)

**The following final adjustment is very important:
Please ensure that your turntable rack is in a levelled position.**

Please check with the bubble level gauge, if your *Master Innovation* turntable is in a levelled position. You can adjust each of the turntable's feet to get the turntable levelled. Only if the turntable is in a levelled position you will get the best results with your *Master Innovation* turntable.



Pic. 18a: Alignment of the turntable

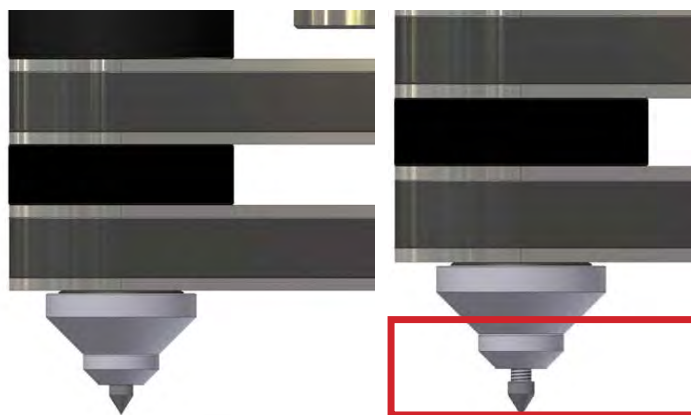

Pic. 18b: Adjustment of the height

15.)

Please connect the mains plug to your power supply.



Pic. 19: Connection power supply and motor

16.)

By pushing the sensor switch, marked with "33 1/3" on the motor, the turntable starts to spin until 33 1/3 rpm is reached.

After the initial setup we recommend to let the turntable spin for at least 15 to 30 minutes.

This ensures a smoother break in.

4. Fine adjustment of the Master Innovation motor

1.)

The *Master Innovation* is ready to play after ending the modification. But through the rebuilding speed differences could occur, because a complete new turntable is formed. In this case you have to correct the speed. Please proceed as described below.

For the correct adjustment of the speed please put the recommended **Clearaudio Stroboscope Testrecord** on the platter (See accessory pack *Innovation* turntable). Follow hereby the instruction of the *Stroboscope Testrecord* user manual. To check the speed with highest accuracy please use the **Clearaudio Speed Light** (AC039) (www.analogshop.de).

On the front side of your turntable there are three setting trimmers (see pic. 15).



- left trimmer = setting 33 1/3 rpm (near turntable motor)
- middle trimmer = setting 45 rpm
- right trimmer = setting 78 rpm (near turntable bearing)

Pic. 20: Fine adjustment of the motor

If you like to adjust the speed 33 1/3 rpm, take the aluminium screw driver (see accessories) and turn the left trimmer until you have reached the right speed according to the Stroboscope Testrecord (see user manual "Stroboscope Testrecord").

- Turning the trimmer counter clockwise = reduces the turntable speed
- Turning the trimmer clockwise = raises the turntable speed

Please proceed with the speed adjustment for 45 rpm and 78 rpm in the same way!

Please note:

If the turntable does not reach the correct speed, the sensor or the scale ring could be dirty or dusty. To clean the sensor, please take off the two platters very carefully!

Clean the sensor and the scale ring with a little isopropyl alcohol and a cotton bud.

Be careful and avoid any scratches on the sensor or the scale ring!

If the motor has further more speed variations please contact your nearest authorized **Clearaudio** dealer or directly the **Clearaudio** factory.

Now you are finally ready to play your vinyl records.

We wish you a lot of pleasure with your new *Master Innovation* turntable.



5. Special notes

5.1 Maintenance

- If the Master Innovation turntable is to be unused for some time, please disconnect the motor from the main power supply.
- Every two years you can lubricate the bearing of the turntable platter with the bearing oil provided; 1 or 2 drops will be enough.
- If any damage to the power cord should occur, please ensure that this is repaired only by authorized personnel. Please note: A damaged power cord must be exchanged immediately.

Caution!

Please use only non-alcoholic fluids specifically intended for acrylic to clean the *Master Innovation* turntable.

Otherwise damage to the material or the surface can occur. Avoid using dry cloths for cleaning due to electrostatic charging. Suitable cleaning materials are available from **Clearaudio** (www.analogshop.de) or from your local hifi dealer.

5.2 Transportation

- For any required transportation of the *Master Innovation* turntable, please always remove the turntable platter and the shaft holder. Otherwise serious damage may occur. To avoid any dust getting into the bearing, the bearing hole should be covered.
- Please ensure that you send the *Master Innovation* turntable always and only in its original packaging. Without the original packaging, **Clearaudio's** warranty will not be valid. When repackaging the turntable, please follow in reverse the steps indicated in this manual for installation and setup (from section 1).

5.3 Service

Any required servicing of **Clearaudio** products should be carried out by authorized personnel only. In the case of repairs, the *Master Innovation* turntable must be sent to your nearest authorized **Clearaudio** distributor or dealer, or directly to the **Clearaudio** factory:

Clearaudio electronic GmbH

Spardorfer Str. 150
91054 Erlangen
Germany

Phone.: +49 9131 40300 100

Fax: +49 9131 40300 119

www.clearaudio.de

www.analogshop.de

info@clearaudio.de

6. Technical data

Construction principle:	<ul style="list-style-type: none"> - Resonance–optimised chassis shape - Made of bullet proof wood and aluminium with precision CNC machined surface. - All turntable feet are fine adjustable - Optical Speed Control (OSC) - Playback with three tonearms possible
Available speeds:	Electronic speed change, 33 1/3 rpm, 45 rpm, 78 rpm
Drive unit:	<ul style="list-style-type: none"> - High torque DC motor exclusively made for Clearaudio; Optical Speed Control (OSC) in real time through infrared sensor - Decoupled DC motor in chassis; resonance damping device; belt-driven - Magnetic decoupling of turntable and additional drive platter
Bearing:	<ul style="list-style-type: none"> - Clearaudio patented ceramic magnetic bearing (CMB) in main platter / upper drive platter assembly - Inverted bearing in lower drive platter
Platter:	<p>70 mm (2.75 inch) main platter, made out of synthetic material with high density and excellent dimension stability, precision CNC machined surface, solid stainless steel sub-platter, dynamically balanced</p> <p>15 mm (4/5 inch) precision CNC machined dynamically balanced stainless steel sub–platter</p>
Speed variation less than:	< ± 0.05%
Power consumption:	
Max. consumption:	9,5 watts
Consumption in operation:	4,1 watts
Standby mode:	2,4 watts
Off mode:	0,0 watts
Weight:	approx. 60kg (without tonearm and packing)
Dimension (w x d x h):	approx. 460 x 485 x 396mm approx. 18.11 x 19.09 x 15.59 inches
Warranty:	5 years*

* Provided that the warranty card is correctly completed and returned to **Clearaudio** within 14 days of purchase.

Clearaudio electronic is not responsible for typographical errors in descriptions.
 Technical specifications subject to change or improvement without prior notice.
 Product availability is as long as stock lasts.
 Copies and reprints of this documents, including extracts, require written consent from
Clearaudio electronic GmbH; Germany



To benefit from the full **Clearaudio** warranty (5 years for the for the *Master Innovation* turntable), you must fill out and return to **Clearaudio** the corresponding part of the warranty registration within two weeks of purchase.

The *Master Innovation* turntable must be returned in its original packaging. Without the original packaging, **Clearaudio's** warranty will not be valid.

**ENGLISH****WARRANTY**

For warranty information, contact your local **Clearaudio** distributor.

RETAIN YOUR PURCHASE RECEIPT

Your purchase receipt is your permanent record of a valuable purchase. It should be kept in a safe place to be referred to as necessary for insurance purposes or when corresponding with **Clearaudio**.

IMPORTANT

When seeking warranty service, it is the responsibility of the consumer to establish proof and date of purchase. Your purchase receipt or invoice is adequate for such proof.

FOR U.K. ONLY

This undertaking is in addition to a consumer's statutory rights and does not affect those rights in any way.

**FRANÇAIS****GARANTIE**

Pour des informations sur la garantie, contacter le distributeur local **Clearaudio**.

CONSERVER L'ATTESTATION D'ACHAT

L'attestation d'achat est la preuve permanente d'un achat de valeur. La conserver en lieu sûr pour s'y reporter aux fins d'obtention d'une couverture d'assurance ou dans le cadre de correspondances avec **Clearaudio**.

IMPORTANT

Pour l'obtention d'un service couvert par la garantie, il incombe au client d'établir la preuve de l'achat et d'en corroborer la date. Le reçu ou la facture constituent des preuves suffisantes.

**DEUTSCH****GARANTIE**

Bei Garantiefragen wenden Sie sich bitte zunächst an Ihren **Clearaudio** Händler. Heben Sie Ihren Kaufbeleg gut auf. **WICHTIG!**

Die Angaben auf Ihrer Quittung erlauben uns die Identifizierung Ihres Gerätes und belegen mit dem Kaufdatum die Dauer Ihrer Garantie-Ansprüche. Für Serviceleistungen benötigen wir stets die Gerätenummer. Diese finden Sie auf dem Typenschild auf der Rückseite des Gerätes oder auch in der beigefügten Garantie-Registrierkarte.

**NEDERLANDS****GARANTIE**

Voor inlichtingen omtrent garantie dient u zich tot uw plaatselijke **Clearaudio**.

UW KWITANTIE, KASSABON E.D. BEWAREN

Uw kwitantie, kassabon e.d. vormen uw bewijs van aankoop van een waardevol artikel en dienen op een veilige plaats bewaard te worden voor evt. verwijzing bijv. in verbind met verzekering of bij correspondentie met **Clearaudio**.

BELANGRIJK

Bij een evt. beroep op de garantie is het de verantwoordelijkheid van de consument een gedateerd bewijs van aankoop te tonen. Uw kassabon of factuur zijn voldoende bewijs.



ITALIANO

GARANZIA

L'apparecchio è coperto da una garanzia di buon funzionamento della durata di un anno, o del periodo previsto dalla legge, a partire dalla data di acquisto comprovata da un documento attestante il nominativo del Rivenditore e la data di vendita. La garanzia sarà prestata con la sostituzione o la riparazione gratuita delle parti difettose. Non sono coperti da garanzia difetti derivanti da uso improprio, errata installazione, manutenzione effettuata da personale non autorizzato o, comunque, da circostanze che non possano riferirsi a difetti di funzionamento dell'apparecchio. Sono inoltre esclusi dalla garanzia gli interventi inerenti l'installazione e l'allacciamento agli impianti di alimentazione.

Gli apparecchi verranno riparati presso i nostri Centri di Assistenza Autorizzati. Le spese ed i rischi di trasporto sono a carico del cliente. La casa costruttrice declina ogni responsabilità per danni diretti o indiretti provocati dalla inosservanza delle prescrizioni di installazione, uso e manutenzione dettagliate nel presente manuale o per guasti dovuti ad uso continuato a fini professionali.



ESPAÑOL

GARANTIA

Para obtener información acerca de la garantía póngase en contacto con su distribuidor **Clearaudio**.

GUARDE SU RECIBO DE COMPRA

Su recibo de compra es su prueba permanente de haber adquirido un aparato de valor, Este recibo deberá guardarlo en un lugar seguro y utilizarlo como referencia cuando tenga que hacer uso del seguro o se ponga en contacto con **Clearaudio**.

IMPORTANTE

Cuando solicite el servicio otorgado por la garantía el usuario tiene la responsabilidad de demostrar cuándo efectuó la compra. En este caso, su recibo de compra será la prueba apropiada.







Loving music

clearaudio electronic GmbH

Spardorfer Straße 150
91054 Erlangen
Germany

Phone/Tel.: +49 9131 40300 100

Fax: +49 9131 40300 119

www.clearaudio.de

www.analogshop.de

info@clearaudio.de

Handmade in Germany

(Technische Änderungen vorbehalten -
Technical specification are subject to change without prior notification)
2018