

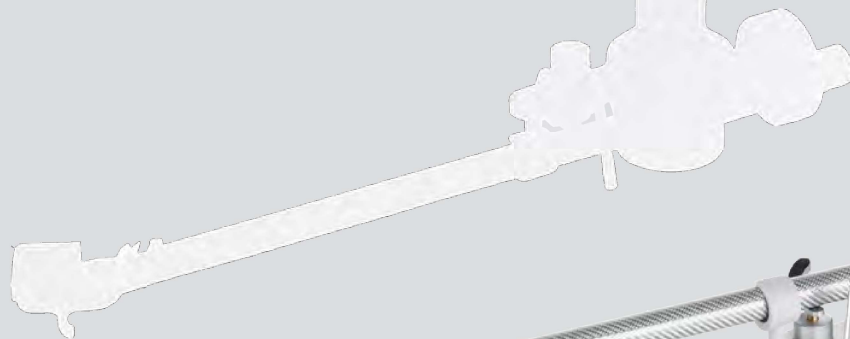

Loving music

Tracer

User manual Bedienungsanleitung

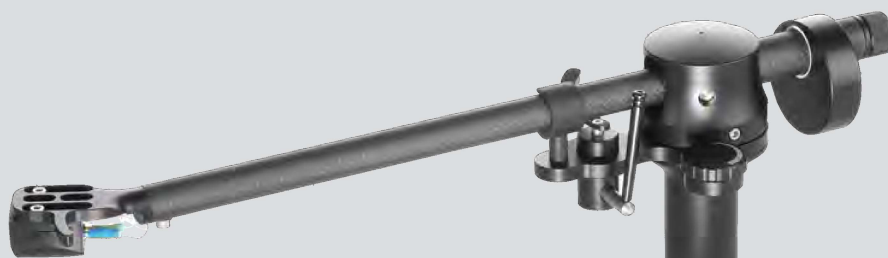

**Pic. similar /
Abb. ähnlich**

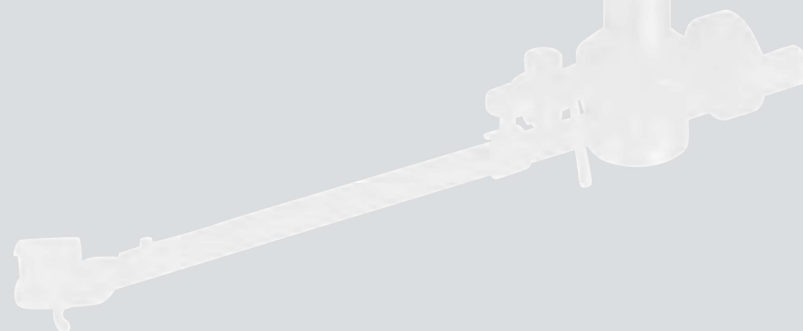

**Pic. similar /
Abb. ähnlich**



User manual 2 - 18



Bedienungsanleitung 19 - 35

Dear **Clearaudio** customer,

Thank you for your decision to purchase the *Tracer* tonearm from **Clearaudio**.
This tonearm is manufactured to the highest degree of tolerance and quality.

Drawing on engineering tricks from the finest watchmakers, it features a high-precision, low friction jeweled bearing, judiciously crafted from tungsten and sapphire. The carbon tonearm tube is both extremely rigid and very lightweight, giving a perfect combination of stability and agility.

The anti-skating force is effortlessly adjustable by way of a simple dial within perfect reach, while the aluminium headshell allows the azimuth to be easily fine-tuned.
The counter-weight is underslung providing an optimal centre of gravity and allowing straight forward adjustment of the tracking force.

Please take a moment to read this owner's manual to ensure correct set-up, to avoid any possible damage and to learn how to take good care of your **Clearaudio** *Tracer* tonearm to ensure that it will give many years of musical enjoyment and pleasure.

Clearaudio wishes you much enjoyment with your new *Tracer* tonearm.

Clearaudio electronic GmbH



Loving music



Safety instructions

1. General information

Check the tonearm for any damage before using it. Do not connect the tonearm if damaged!

Never connect the tonearm if it has been dropped or gotten wet, contact your dealer to have the tonearm checked.

Never expose the tonearm to rain or moisture.

The inside of the tonearm is maintenance free. Never open the case or attempt to repair the unit yourself, since this can lead to loss of warranty!

Before using the tonearm for the first time or after a long period of inactivity the lift must be operated approx. 4-5 times to loosen the grease in the tonearm lift to lower the lift bar evenly again.

Not suitable for children! Scope of delivery may contain small parts that can be swallowed.

2. Intended use

The *Tracer* is a tonearm for playing music and is intended exclusively for use on turntables.

Only use the *Tracer* tonearm in accordance with the information provided in the user manual.

3. Location of installation

Avoid locations with direct sunlight, temperature fluctuations and high humidity. Likewise, avoid placing electronic devices near heaters, heat lamps, or other devices that produce heat.

The device is designed for operation at room temperature.

No objects with an open flame may be placed on or near the device (burning candles or similar).

4. Maintenance

We recommend that you move the tonearm lift at regular intervals to keep the bearing grease supple and to prevent the tonearm from getting stuck during playback if you do not use your **Clearaudio** tonearm for a longer period.

Never use aggressive cleaning agents.

Do not use dry cloths for cleaning as this generates static electricity. Suitable cleaning and care products from **Clearaudio** are available at www.analogshop.de or from specialist retailers.

Only use a soft cloth with a smooth surface or a soft brush for cleaning.

5. Health information

Permanently high volume can lead to various types of hearing damage. Use high volume responsibly!

6. Service

The *Tracer* tonearm should be repaired during the guarantee period by the manufacturer only, otherwise the warranty claim expires. All **Clearaudio** products should only be serviced by specialist retailer.

If, despite the high production standard, a service is necessary, the *Tracer* tonearm must be send to **Clearaudio** through your dealer.

7. Transport

Use the original packing material for further transportation of the *Tracer* tonearm, otherwise serious damage could occur.

Be sure to pack the device exactly as it was shipped.
Safe transport is only guaranteed in the original packaging.

Proceed in reverse as described for assembly when packing.

8. Disposal



Do not dispose this product together with other waste.
WEEE Reg. No.: DE26004446

9. CE Marking



This electronic product corresponds to the applicable guidelines for obtaining the CE mark.



Contents

1. List of components	6
2. Mounting the tonearm base	
2.1 Mounting the tonearm base on the Clearaudio Performance DC or Ovation turntable.....	7
2.2 Mounting the tonearm base on a Clearaudio Innovation series turntable	8
2.3 Mounting the clamping ring on a other manufacturers' turntables.....	9
3. Mounting the <i>Tracer</i> tonearm without VTA-Lifter	10
4. Adjustment of the distance between spindle and pivot point.....	11
5. Adjustment of the tonearm	11
5.1 Adjustment of the VTA	12
5.2 Alignment and adjustment of the cartridge.....	13
5.3 Adjustment of the tracking force	14
5.4 Adjustment of the azimuth.....	15
5.5 Adjustment of the anti-skating	16
6. Troubleshooting.....	17
7. Technical data.....	18
Warranty.....	36 - 37

1. List of components

Clearaudio has developed a special and secure packing for your *Tracer* tonearm that ensures safe transportation. Please retain the original packaging for any future transportation and shipping.

Please check the contents as shown in the picture below and in the list at the bottom of this page.

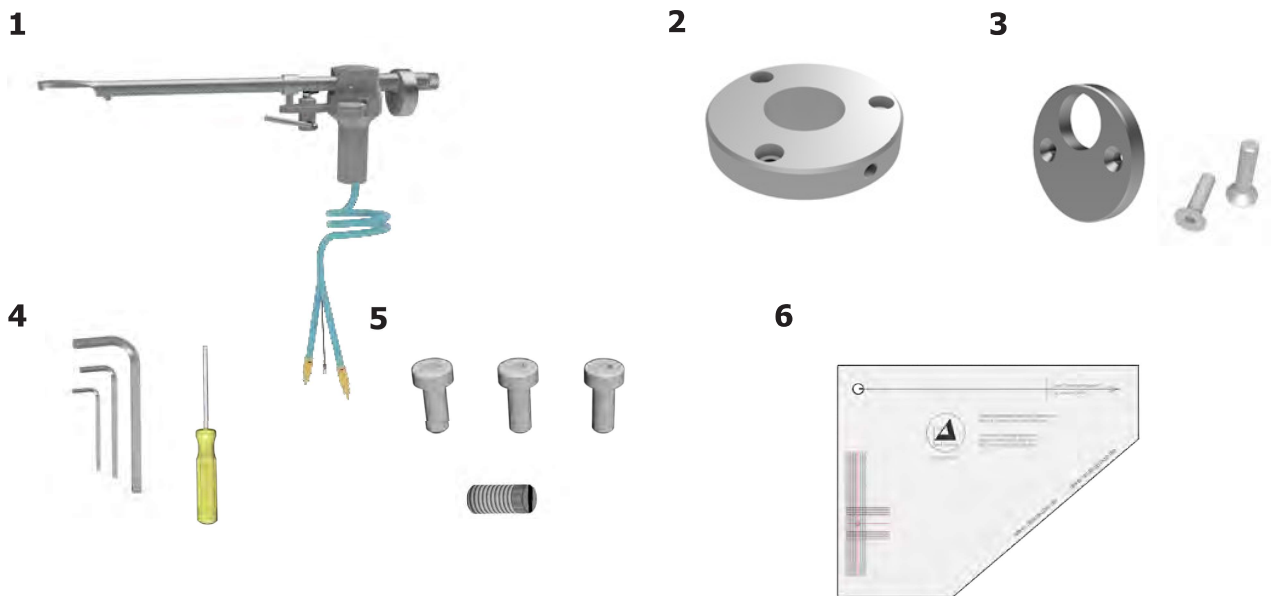

Pic. 1: List of components

1.	<i>Tracer</i> tonearm incl. counterweight	5.	Screws: - 3 pcs. hex screw M4 x 10 - 1 pcs. grub screw M6 x 8
2.	Clearaudio clamping ring	6.	Paper tonearm alignment template
3.	1 pcs. additional counterweight 37g 2 pcs. flat head screw (3 x 8mm)	7.	User manual, quality certificate, warranty card and return delivery note (not shown)
4.	3x hex wrench: - 1.5mm - 2.5mm - 3mm Screwdriver		

Recommended Tools:

- **Clearaudio** Cartridge alignment gauge (Art. No. AC005/IEC)
- **Clearaudio** Weight Watcher touch (Art. No. AC163)
- **Clearaudio** Mini Level Gauge (Art. No. AK001)

This items and more accessories are available through your dealer or at www.analogshop.de.

2. Mounting the tonearm base

2.1 Mounting the tonearm base on the Clearaudio Performance DC or Ovation turntable

Please check if the correct tonearm base is mounted on your turntable (Pic. 2).

Please note that you will need a different tonearm base, if you want to mount the *Tracer* tonearm in combination with the VTA-Lifter (Pic. 3).

If the wrong tonearm base is mounted place the turntable on the edge of a table or similar surface to gain access to the tonearm base from below.

Remove the tonearm base by loosening the six M4 x 35mm screws with a hex wrench on the bottom side of the clamping ring.

Exchange the tonearm base and loosely tighten the screws to keep the tonearm base rotatable. Please ensure the perfect location of the base.

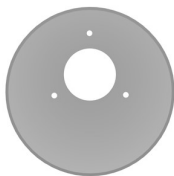

Without VTA-Lifter

To mount the tonearm without VTA-Lifter, you need the tonearm base AC031-4 (Pic. 2)

Pic. 2: Tonearm base for Performance DC & Ovation without VTA-Lifter (Art. No. AC031-4)

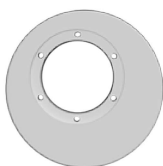

With VTA-Lifter

To mount the tonearm in combination with VTA-Lifter, you need the tonearm base AC031-8 (Pic.3).

Pic. 3: Tonearm base for Performance DC & Ovation with VTA-Lifter (Art. No. AC031-8)

2.2 Mounting the tonearm base on a Clearaudio Innovation series turntable

Please check that the correct tonearm base is mounted on your turntable (Pic. 4).

Please note that you will need a different tonearm base, if you want to mount the *Tracer* tonearm in combination with the VTA-Lifter (Pic. 5).

If the tonearm base is already pre-assembled, it is in a position which is optimized for the packaging. The position of the tonearm base will be correct during the adjustment of the tonearm.

If not, remove the previous tonearm base by loosening the screw of the aluminium base with a 7mm hex wrench.

Exchange the tonearm base against the correct one and place it as seen in picture 6.

Now you can loosely tighten it so that the tonearm base is still rotatable.



Without VTA-Lifter

To mount the tonearm without VTA-Lifter, you need the tonearm base AC030-4 (Pic. 4).

Pic. 4: Tonarme base for Innovation Serie (Art. No. AC030-4)



With VTA-Lifter

To mount the tonearm in combination with VTA-Lifter, you need the tonearm base AC030-10 (Pic. 5).

Pic. 5: Tonarm base for Innovation Serie (Art. No. AC030-10)

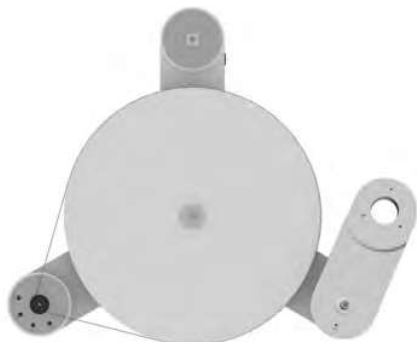

Pic. 6: Rough alignment of the tonearm base

2.3 Mounting the clamping ring on a other manufacturers' turntables

Drill three holes into the turntable chassis to mount the aluminium clamping ring.

Use the measurements given in the drawing template below to ensure the correct position of the three holes (Pic. 3).

Use a 3.3mm drill for this step. After you have drilled the three holes, thread the holes using an appropriate tap cutter. If the material of the turntable chassis is not suitable for threading, please use a 4.5mm drill for the holes. In this case, you will need longer screws with nuts to fit the tonearm base.

Please note that this image is not true to scale.

**Please note:
This drilling template is only suitable for 9 inch tonearms.**

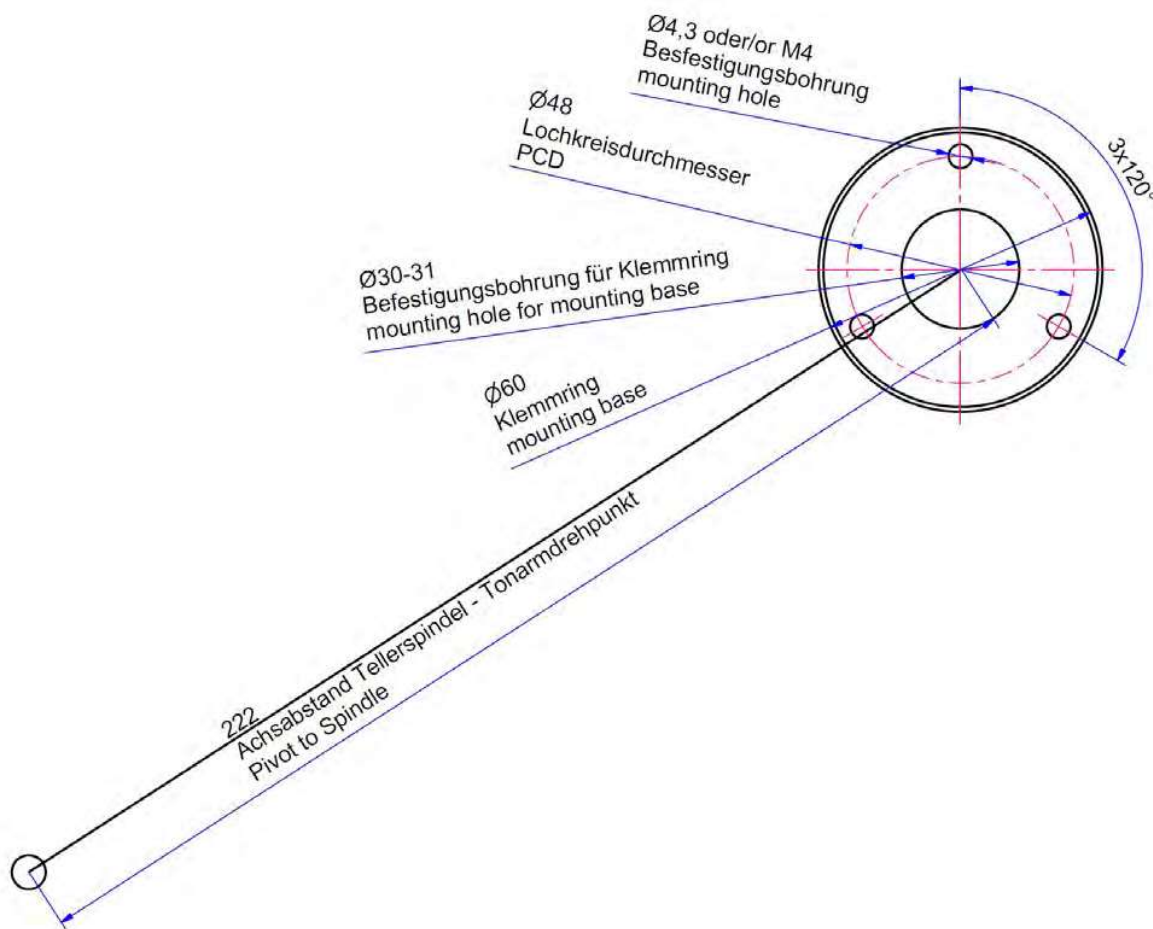

Pic. 7: Drilling template for mounting the tonearm base on a other manufacturers' turntable

3. Mounting the *Tracer* tonearm without VTA-Lifter

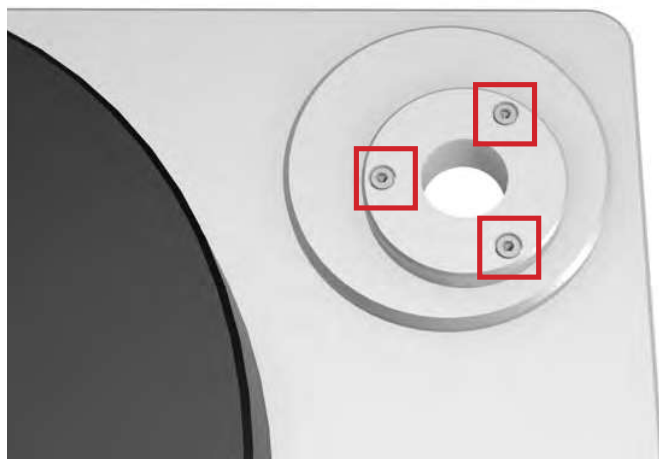

Pic. 8: Mounting the clamping ring

Take the clamping ring and place it on the recess in the tonearm base.

Now you can attach the clamping ring to the tonearm base with the 3 supplied M4 x 10 screws.

Make sure that the side hole of the clamping ring remains accessible (see Pic. 9).



Pic. 9: Mounting the tonearm

First insert the tonearm cable and then the tonearm foot of the *Tracer* tonearm into the hole of the clamping ring.

Now fix the tonearm with the screws and the hex wrench. Do not over-tighten for later adjustments!

To assemble the *Tracer* tonearm with VTA-Lifter, please follow the separate user manual for the VTA-Lifter.

4. Adjustment of the distance between spindle and pivot point

We recommend to use the **Clearaudio** alignment gauge (Art. No. AC005/IEC, also available from www.analogshop.de) for the exact setting of the tonearm pivot point.

Make sure that the distance between spindle and the pivot point of the tonearm is exactly 222mm. You can adjust the distance by rotating the tonearm base.

Please tighten the tonearm base and check the measurement again after adjustment.

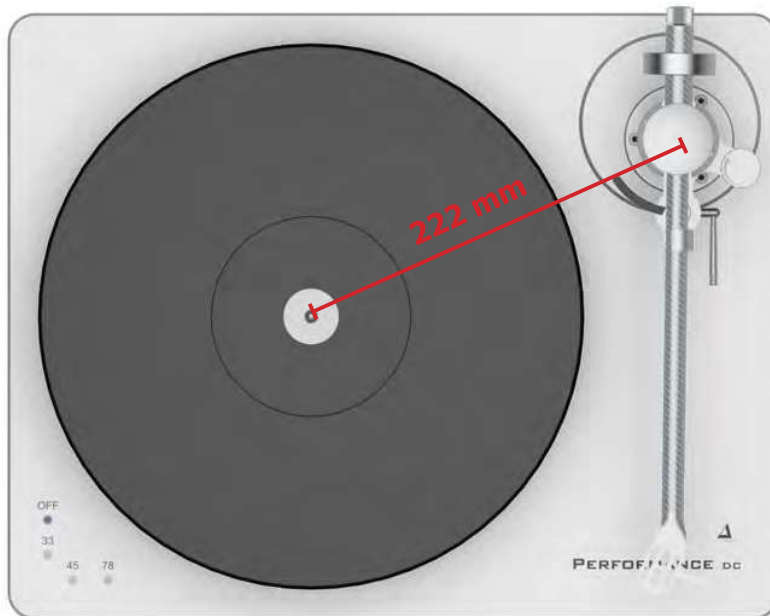

Pic. 10: Distance from pivot to spindle

5. Adjustment of the tonearm

The following settings require to mount the cartridge on the headshell. Always follow the cartridge manufacturer's instructions.

Leave the stylus protector on your cartridge to avoid any damages!

Now you can connect the respective signal cable with the matching color pins of the cartridge. Please note the following colour coding:

Red: right channel / R+
Green: right channel / R-
White: left channel / L+
Blue: left channel / L-

Connect the pins of your cartridge to the jacks of the headshell or tonearm cable, taking care not to use too much force.

Use suitable precision pliers or tweezers for assistance if necessary.

5.1 Adjustment of the VTA

The tonearm remains loose in the clamping ring and is not screwed tight. Now place a record or the **Clearaudio** alignment gauge (Art. No. AC005/IEC) on the turntable and remove the stylus protector from your cartridge.

Make sure that the tracking force is roughly adjusted in order not to damage the cartridge.

**Please be extremely careful during the following steps!
Never move the cartridge in the alignment gauge while it is lowered.**

Use the lift to lower the tonearm and check if the tonearm tube is parallel to the platter.

The tonearm tube should not touch the lift bracket, but the needle must rest on the record or the alignment gauge.

Put the tonearm tube back in the rest position if the tonearm tube is not parallel and shows a slight incline.

Now carefully lower/raise the entire tonearm in the clamping ring until the tonearm tube is parallel to the platter.

Hand-tighten the clamping ring while the tonearm is in this position.

Put the tonearm back in the rest position holder and add the stylus protector if the position is still correct.

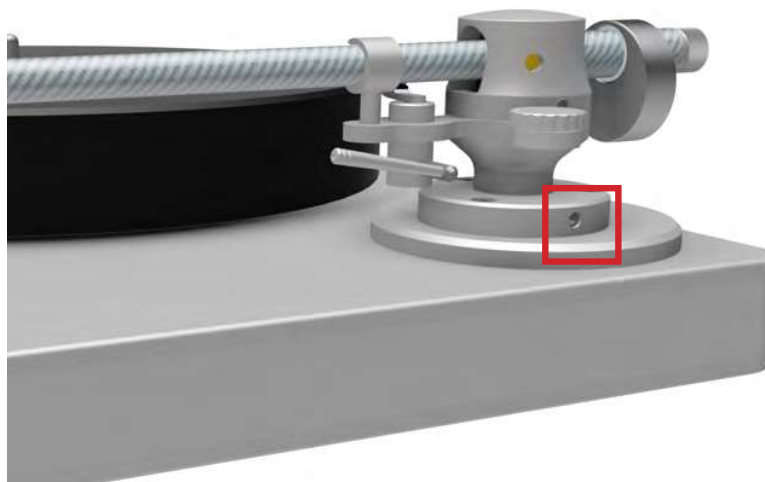

Pic. 11: Fixing the tonearm height

5.2 Alignment and adjustment of the cartridge

Use the adjustment template, included in the scope of the delivery for the final tonearm and cartridge adjustment.

Place it directly on the turntable (without record) and align it with the arrow pointing toward the tonearm pivot point (Pic. 12).

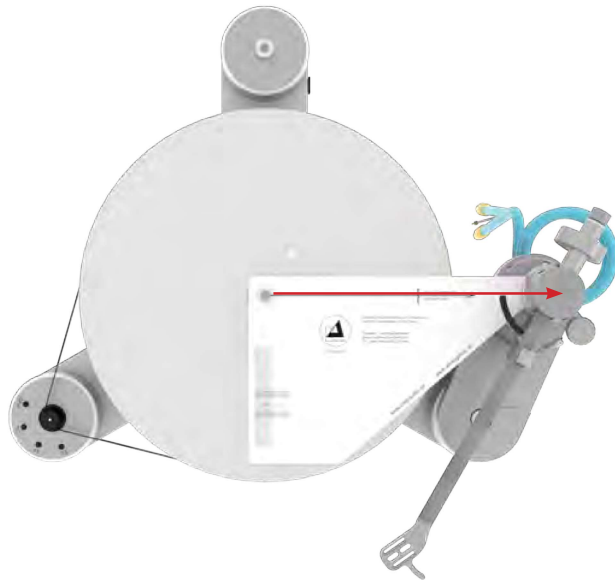

Pic. 12: Placing the adjustment template

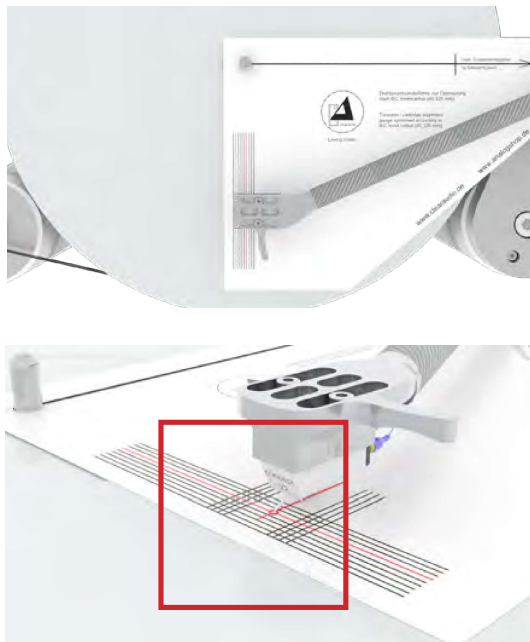

Take the tonearm out of the rest position and align it in the area of the cross lines.
Lower the tonearm and check the alignment.

The cartridge body must be aligned in the template grid and the needle tip should be located in the cross lines.

Also, the side and front edges of the housing have to be parallel to the grid lines.

To correct the adjustment, loosen the screws of the cartridge to move the cartridge in the headshell.

Re-check the setting again after you have tightened the screws.

Pic. 13: Correct alignment of the cartridge

5.3 Adjustment of the tracking force

Turn the adjustment screw at the end of the tonearm to increase or lower the tracking force.

Green arrow = Higher tracking force

Red arrow = Lower tracking force

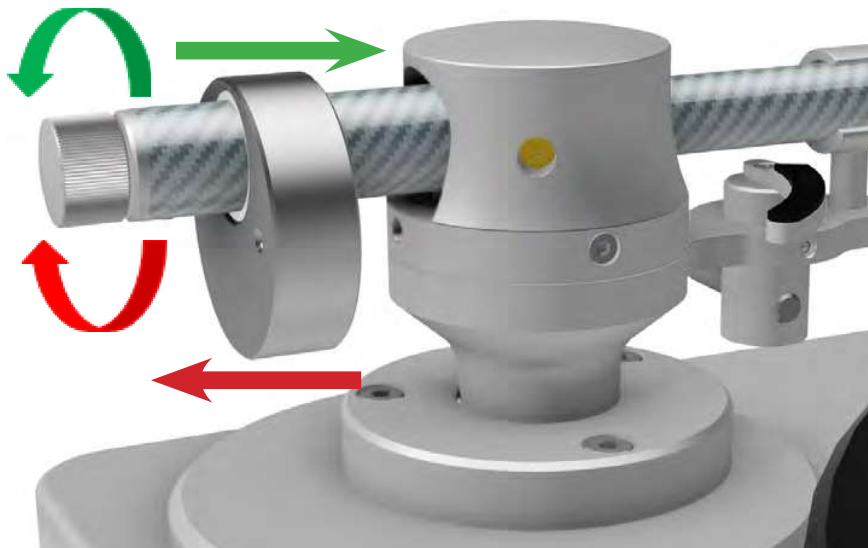

Pic. 14: Adjustment of the tracking force

5.4 Adjustment of the azimuth

The azimuth is the angle of the cartridge stylus to the record surface. Viewed from the front, the cartridge needle has to be vertical to the record.

Please note: The azimuth is already set at the factory.

Lower the cartridge onto the record surface and check the position of the needle if you still want to optimize the azimuth.

Please proceed as following to change the azimuth:

Loosen the screw (hex wrench #2) on the bottom side of the tonearm tube near the headshell. Now you can adjust the azimuth by turning the headshell in the tonearm tube.

Carefully tighten the small hex screw again without changing the previously selected position.

We recommend the "Mini Level Gauge" from **Clearaudio** (Art.No.: AK001; also available from www.analogshop.de) to check the adjustment.

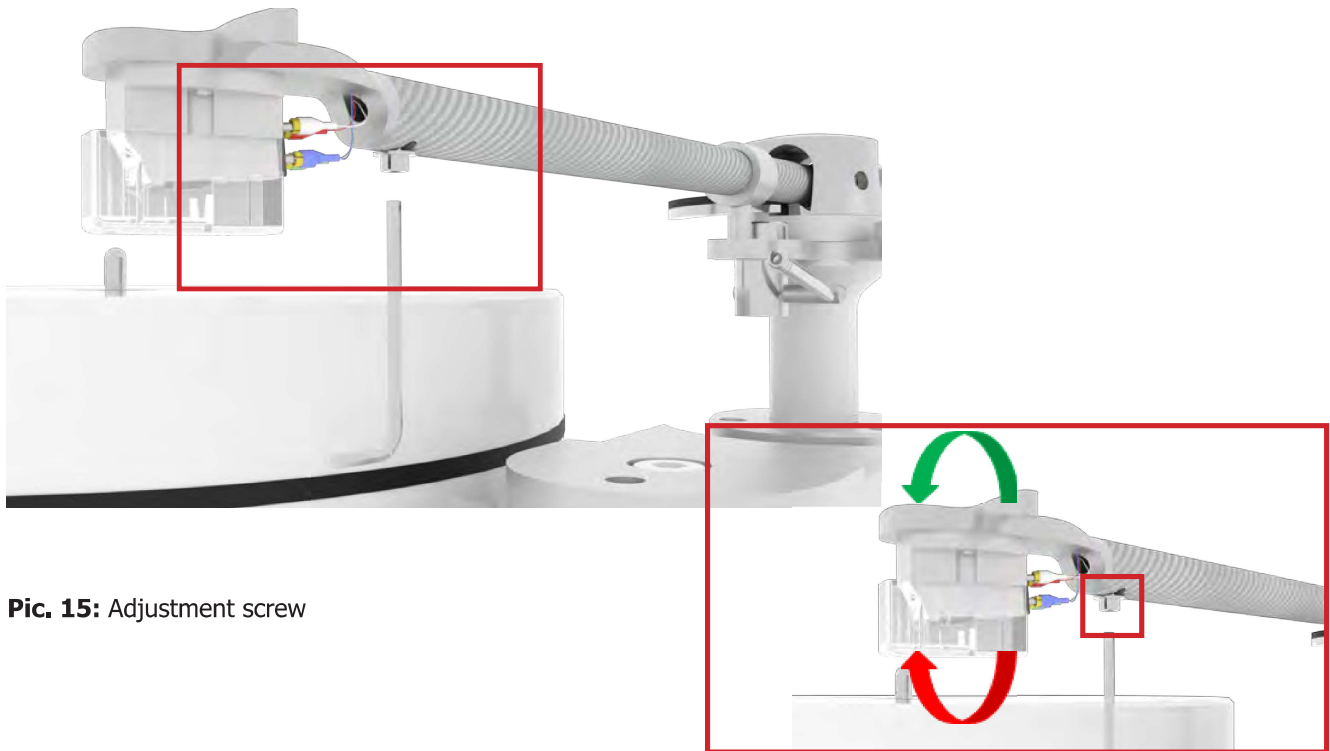

Pic. 15: Adjustment screw

Pic. 16: Loosening the screw

5.5 Adjustment of the anti-skating

You can adjust the anti-skating setting by adjusting the anti-skating screw (Pic. 17 / 1, 2, 3). The level of anti-skating force required will depend on the tracking force of the cartridge.

We recommend the **Clearaudio** Trackability Test Record available from www.analogshop.de or from your specialist retailer for a professional and perfect anti-skating setting.

<u>Level of anti-skating:</u>		<u>tracking force</u>		<u>position of the antiksating screw</u>
minimal anti-skating	>>	10-15mN	>>	see illustration 1
medium anti-skating	>>	15-20mN	>>	see illustration 2
maximum anti-skating	>>	20mN and more	>>	see illustration 3

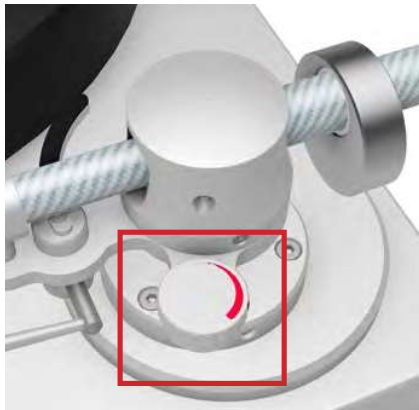

Illustration 1
(minimal anti-skating)

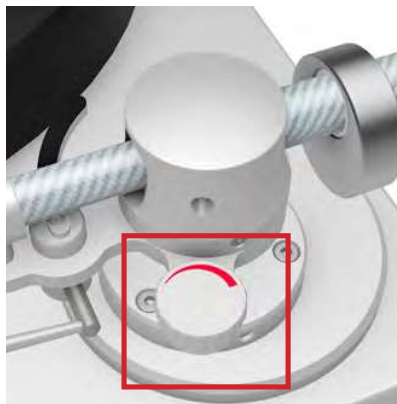

Illustration 2
(medium anti-skating)

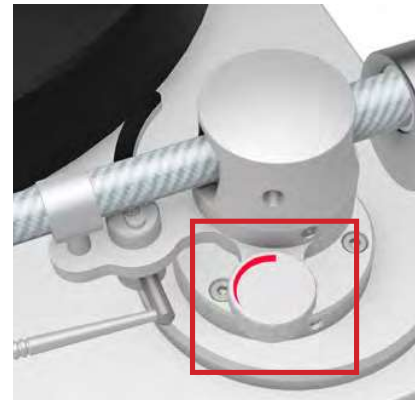

Illustration 3
(maximum anti-skating)

Pic. 17: Anti-skating adjustment

The general setup is now completed.

We recommend to re-check all settings again and correct them if necessary before connecting the tonearm to your phono pre-amplifier.

Clearaudio wishes you a lot of joy fun with your new *Tracer* tonearm.



6. Troubleshooting

First check the possible causes to rule out incorrect operation if you have a problem with your *Tracer* tonearm.

Please contact your dealer if the error persists!

Never try to open the unit and/or repair it yourself, this will void the warranty!

Error	Cause	Measure
Needle bounces or slides across record	Is the record or the stylus dirty or damaged?	Clean the record / or the cartridge. Clearaudio offers many helpful accessories for care and cleaning. In the event of damage, we recommend an assessment by a specialist and, if necessary, an exchange.
	Has the tracking force been set too high?	Adjust the tracking force. Use only a suitable gauge! For example Clearaudio „Weight Watcher touch“ or „Smart Stylus Gauge“.
	Is the record deformed or scratched?	Use a record clamp or replace the record.
	Is the turntable leveled?	Check the alignment of the turntable and adjust if necessary.
Tonearm lift does not lower or lowers very slowly	The tonearm has not been used for a long time, which means that the grease in the tonearm lift can harden and lower with difficulty.	Operate the lift about 4-5 times to loosen the grease in the tonearm lift and the lift bar will lower evenly again.

7. Technical data

Construction details:	Radial tonearm Horizontal sapphire bearing and vertically ball bearing
Material:	Aluminium (black/silver), stainless steel, carbon tonearm tube (black/silver)
Cartridge balance range:	3.5g - 17.0g
Overhang:	17.12mm
Total length:	320.00mm
Effective length:	239.12mm
Mounting distance (tonearm pivot to spindle):	222.00mm
Offset angle:	25.00°
Wiring:	1.1m Clearaudio Super Sixstream terminated with RCA
Weight:	Approx. 500g (incl. counterweight)
Manufacturer's warranty:	3 years*

* Provided that the warranty card is correctly completed and returned to **Clearaudio** or your product is registered online at <https://clearaudio.de/en/service/registration.php>, within 14 days of purchase.

The full, extended warranty period for the *Tracer* tonearm is 3 years. To receive this full **Clearaudio** warranty, you must either complete and return the relevant section of the warranty registration card to **Clearaudio**, or register your product online at <https://clearaudio.de/en/service/registration.php>, within 14 days of purchase. Otherwise only the legal warranty can be considered.

The full 3 year warranty can only be honoured if the product is returned in its original packing.

Um die volle **clearaudio** Garantie (für *Tracer* 3 Jahre) in Anspruch nehmen zu können, senden Sie uns bitte die beigelegte Garantiekarte innerhalb von zwei Wochen korrekt und vollständig ausgefüllt zu oder registrieren Sie die Garantie online unter <https://clearaudio.de/de/service/registration.php>, da sonst nur die gesetzliche Gewährleistung berücksichtigt werden kann. Nur wenn das Produkt in der Originalverpackung zurückgeschickt wurde kann **clearaudio** die Garantiezeit von 3 Jahren gewährleisten.

ENGLISH WARRANTY

For warranty information, contact your local **Clearaudio** distributor.

RETAIN YOUR PURCHASE RECEIPT

Your purchase receipt is your permanent record of a valuable purchase. It should be kept in a safe place to be referred to as necessary for insurance purposes or when corresponding with **Clearaudio**.

IMPORTANT

When seeking warranty service, it is the responsibility of the consumer to establish proof and date of purchase.

Your purchase receipt or invoice is adequate for such proof.

FOR U.K. ONLY

This undertaking is in addition to a consumer's statutory rights and does not affect those rights in any way.

FRANÇAIS GARANTIE

Pour des informations sur la garantie, contacter le distributeur local **Clearaudio**.

CONSERVER L'ATTESTATION D'ACHAT

L'attestation d'achat est la preuve permanente d'un achat de valeur. La conserver en lieu sûr pour s'y reporter aux fins d'obtention d'une couverture d'assurance ou dans le cadre de correspondances avec **Clearaudio**.

IMPORTANT

Pour l'obtention d'un service couvert par la garantie, il incombe au client d'établir la preuve de l'achat et d'en corroborer la date. Le reçu ou la facture constituent des preuves suffisantes.

DEUTSCH GARANTIE

Bei Garantiefragen wenden Sie sich bitte zunächst an Ihren **Clearaudio** Händler. Heben Sie Ihren Kaufbeleg gut auf. **WICHTIG!**

Die Angaben auf Ihrer Quittung erlauben uns die Identifizierung Ihres Gerätes und belegen mit dem Kaufdatum die Dauer Ihrer Garantie-Ansprüche. Für Serviceleistungen benötigen wir stets die Gerätenummer. Diese finden Sie auf dem Typenschild auf der Rückseite des Gerätes oder auch in der beigelegten Garantie-Registrierkarte.

NEDERLANDS GARANTIE

Voor inlichtingen omtrent garantie dient u zich tot uw plaatselijke **Clearaudio**.

UW KWITANTIE, KASSABON E.D. BEWAREN

Uw kwitantie, kassabon e.d. vormen uw bewijs van aankoop van een waardevol artikel en dienen op een veilige plaats bewaard te worden voor evt, verwijzing bijv, in verbend met verzekering of bij correspondentie met **Clearaudio**.

BELANGRIJK

Bij een evt, beroep op de garantie is het de verantwoordelijkheid van de consument een gedateerd bewijs van aankoop te tonen. Uw kassabon of factuur zijn voldoende bewijs.



Loving music

User manual / Bedienungsanleitung



ITALIANO GARANZIA

L'apparecchio è coperto da una garanzia di buon funzionamento della durata di un anno, o del periodo previsto dalla legge, a partire dalla data di acquisto comprovata da un documento attestante il nominativo del Rivenditore e la data di vendita. La garanzia sarà prestata con la sostituzione o la riparazione gratuita delle parti difettose. Non sono coperti da garanzia difetti derivanti da uso improprio, errata installazione, manutenzione effettuata da personale non autorizzato o, comunque, da circostanze che non possano riferirsi a difetti di funzionamento dell'apparecchio. Sono inoltre esclusi dalla garanzia gli interventi inerenti l'installazione e l'allacciamento agli impianti di alimentazione.

Gli apparecchi verranno riparati presso i nostri Centri di Assistenza Autorizzati. Le spese ed i rischi di trasporto sono a carico del cliente. La casa costruttrice declina ogni responsabilità per danni diretti o indiretti provocati dalla inosservanza delle prescrizioni di installazione, uso e manutenzione dettagliate nel presente manuale o per guasti dovuti ad uso continuato a fini professionali.



ESPAÑOL GARANTIA

Para obtener información acerca de la garantía póngase en contacto con su distribuidor **Clearaudio**.

GUARDE SU RECIBO DE COMPRA

Su recibo de compra es su prueba permanente de haber adquirido un aparato de valor, Este recibo deberá guardarlo en un lugar seguro y utilizarlo como referencia cuando tenga que hacer uso del seguro o se ponga en contacto con **Clearaudio**.

IMPORTANTE

Cuando solicite el servicio otorgado por la garantía el usuario tiene la responsabilidad de demostrar cuándo efectuó la compra. En este caso, su recibo de compra será la prueba apropiada.





Loving music

clearaudio electronic GmbH

Spardorfer Straße 150
91054 Erlangen
Germany

Phone /Tel.: +49 9131 40300 100

Fax: +49 9131 40300 119

www.clearaudio.de

www.analogshop.de

info@clearaudio.de



Handmade in Germany

Clearaudio Electronic accepts no liability for any misprints.

Technical specifications are subject to change or improvement without prior notice.

Product availability is as long as astock lasts.

Copies and reprints of this document, including extracts, require written consent from

Clearaudio Electronic GmbH, Germany.

Änderungen bleiben vorbehalten. Lieferbar solange Vorrat reicht. Für Druckfehler keine Haftung.
Irrtümer vorbehalten- Kopien und Abdrucke – auch nur auszugsweise – bedürfen der schriftlichen
Genehmigung durch die **clearaudio electronic GmbH.**

2024