



Loving music

# Universal / Universal 12"

User manual  
Bedienungsanleitung



**Pic. similar /  
Abb. ähnlich**



**Pic. similar /  
Abb. ähnlich**



**User manual ..... 2 - 20**



**Bedienungsanleitung..... 21 - 39**

Dear **Clearaudio** customer,

thank you for your purchase of **Clearaudio's** *Universal* tonearm, one of the best radial tonearm`s available in the world of high end audio.

The *Universal* tonearm is manufactured with the highest degree of tolerance and quality.

This product has been developed with a focus on excellent quality, functionality and ease of use. Please take a moment to read this product manual to ensure correct set-up and to avoid any possible damage.

**Clearaudio** wishes you much enjoyment with your new *Universal* tonearm.

You're **Clearaudio** team



## Safety instructions

### 1. General information

Check the tonearm for any damage before using it. Do not connect the tonearm if damaged!

Never connect the tonearm if it has been dropped or gotten wet, contact your dealer to have the tonearm checked.

Never expose the tonearm to rain or moisture.

The inside of the tonearm is maintenance free. Never open the case or attempt to repair the unit yourself, since this can lead to loss of warranty!

Before using the tonearm for the first time or after a long period of inactivity the lift must be operated approx. 4-5 times to loosen the grease in the tonearm lift to lower the lift bar evenly again.

### 2. Intended use

The *Universal* is a tonearm for playing music and is intended exclusively for use on turntables.

Only use the *Universal* tonearm in accordance with the information provided in the user manual.

### 3. Location of installation

Avoid locations with direct sunlight, temperature fluctuations and high humidity. Likewise, avoid placing electronic devices near heaters, heat lamps, or other devices that produce heat.

The device is designed for operation at room temperature.

No objects with an open flame may be placed on or near the device (burning candles or similar).

### 4. Maintenance

We recommend that you move the tonearm lift at regular intervals to keep the bearing grease supple and to prevent the tonearm from getting stuck during playback if you do not use your **Clearaudio** tonearm for a longer period.

Never use aggressive cleaning agents.

Do not use dry cloths for cleaning as this generates static electricity. Suitable cleaning and care products from **Clearaudio** are available at [www.analogshop.de](http://www.analogshop.de) or from specialist retailers.

Only use a soft cloth with a smooth surface or a soft brush for cleaning.

## 5. Health information

Permanently high volume can lead to various types of hearing damage. Use high volume responsibly!

## 6. Service

The *Universal* tonearm should be repaired during the guarantee period by the manufacturer only, otherwise the warranty claim expires. All **Clearaudio** products should only be serviced by specialist retailer.

If, despite the high production standard, a service is necessary, the *Universal* tonearm must be send to **Clearaudio** through your dealer.

## 7. Transport

Use the original packing material for further transportation of the *Universal* tonearm, otherwise serious damage could occur.

Be sure to pack the device exactly as it was shipped.  
Safe transport is only guaranteed in the original packaging.

Proceed in reverse as described for assembly when packing.

## 8. Disposal



Do not dispose this product together with other waste.  
WEEE Reg. No.: DE26004446

## 9. CE Marking



This electronic product corresponds to the applicable guidelines for obtaining the CE mark.



## Contents

<b>1. List of components .....</b>	<b>6 - 7</b>
<b>2. Mounting the tonearm base .....</b>	<b>8 - 11</b>
2.1 Mounting the tonearm base on the Clearaudio Performance DC / Ovation turntable	
2.2 Mounting the tonearm base on a Clearaudio Innovation series turntable	
2.3 Mounting the clamping ring on a other manufacturer's turntable	
2.4 Mounting the VTA-Lifter on a other manufacturer's turntable	
<b>3. Mounting the Universal tonearm without VTA-Lifter .....</b>	<b>12</b>
<b>4. Adjustment of the distance between spindle and pivot point .....</b>	<b>12</b>
<b>5. Adjustment of the <i>Universal</i> tonearm .....</b>	<b>13 - 18</b>
5.1 Adjustment of the VTA	
5.2 Alignment of the tonearm	
5.3 Alignment and adjustment of the cartridge	
5.4 Adjustment of the tracking force	
5.5 Adjustment of the azimuth	
5.6 Adjustment of the antiskating	
<b>6. Troubleshooting .....</b>	<b>19</b>
<b>7. Technical details.....</b>	<b>20</b>
<b>Warranty information.....</b>	<b>40 - 41</b>

## 1. List of components

The **Clearaudio** *Universal* tonearm is delivered in a customized packing to ensure its safe transport. Please retain the original packaging for any future transportation and shipping.

Please see the list below to check the contents of your **Clearaudio** *Universal* tonearm.

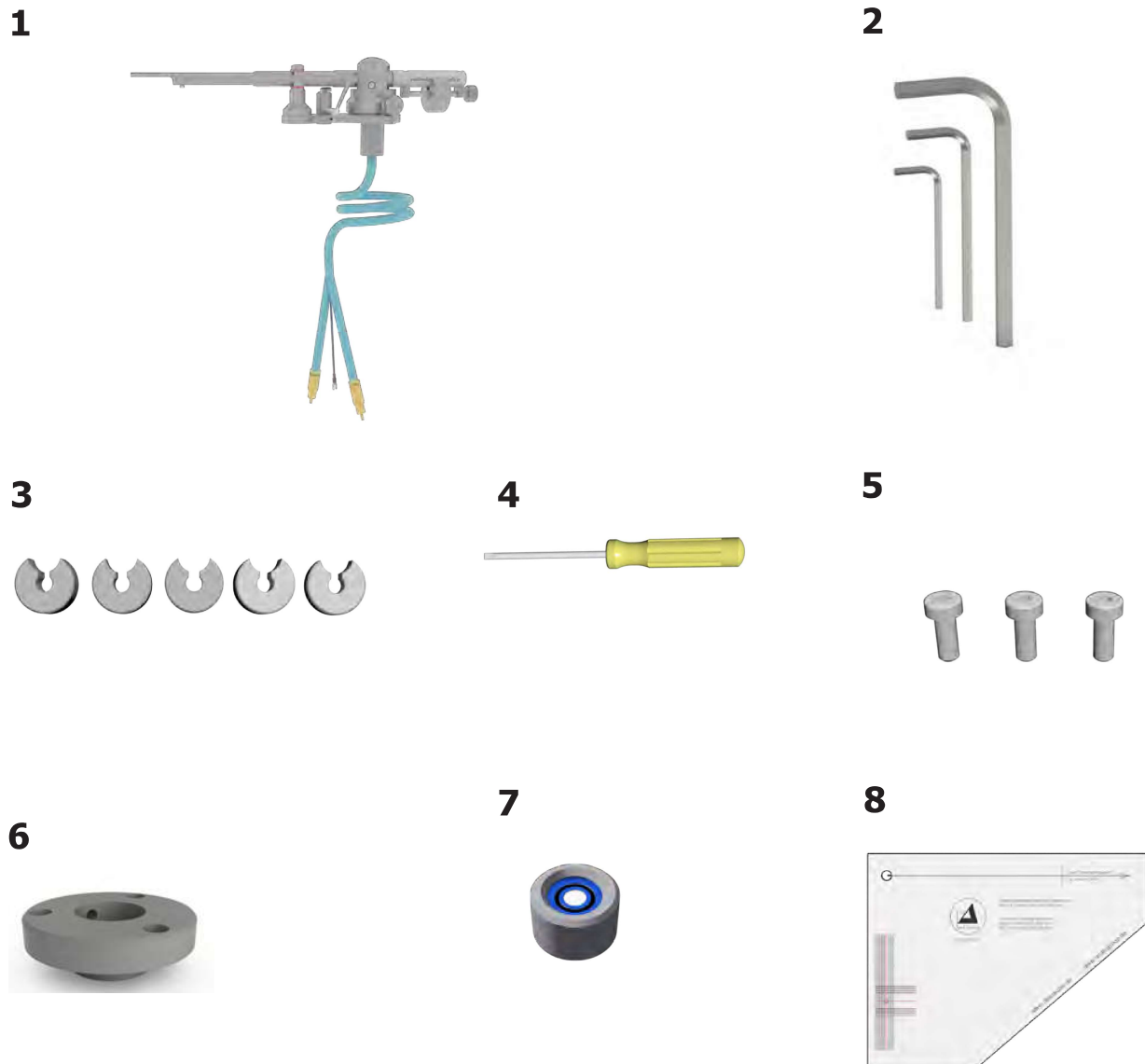

**Pic. 1:** List of components (Pic. similar)



Loving music

## User manual / Bedienungsanleitung

1.	<i>Universal 9 inch</i> tonearm with pre-mounted counterweight (49g) or <i>Universal 12 inch</i> tonearm with pre-mounted counterweight (66g) optional: with VTA-Lifter (separately packed)	6.	Clamping base (incl. pre-mounted screw M6 x 8)
2.	Hex wrench (# 1.5 / 2 / 3)	7.	Mini Level Gauge
3.	Counterweights for <i>Universal 9"</i> : - 18.3g (Aluminium) - 31.5g (Aluminium) - 49g (Stainless steel) (pre-mounted) - 66g (Stainless steel) - 85g (Stainless steel)  Counterweight for <i>Universal 12"</i> : - 49g (Stainless steel) - 66g (Stainless steel) (pre-mounted) - 85g (Stainless steel)	8.	Tonearm alignment gauge
4.	Aluminium screw driver	9.	Without picture: Warranty Card, <b>Clearaudio</b> Quality Card, user manual, return delivery note
5.	Screws for clamping ring - 3pcs M4 x 10		

### Recommended Tools:

- **Clearaudio** Cartridge alignment gauge (Art. No. AC005/IEC)
- **Clearaudio** Weight Watcher touch (Art. No. AC163)

Both items and more accessories are available through your dealer or at [www.analogshop.de](http://www.analogshop.de).

## 2. Mounting the tonearm base

### 2.1 Mounting the tonearm base on the Clearaudio Performance DC or Ovation turntable

Please check that the correct tonearm base is mounted on your turntable (Pic. 2).

Please note that you will need a different tonearm base, if you want to mount the *Universal* tonearm in combination with the VTA-Lifter (Pic. 3).

If the wrong tonearm base is mounted place the turntable on the edge of a table or similar surface to gain access to the tonearm base from below.

Remove the tonearm base by loosening the six M4 x 35mm screws with a hex wrench on the bottom side of the clamping ring.

Exchange the tonearm base and loosely tighten the screws to keep the tonearm base rotatable. Please ensure the perfect location of the base.



#### **Without VTA-Lifter**

To mount the tonearm without VTA-Lifter, you need the tonearm base AC031-5 (Pic. 2)

**Pic. 2:** Tonearm base for Performance DC & Ovation (Art. No. AC031-5)

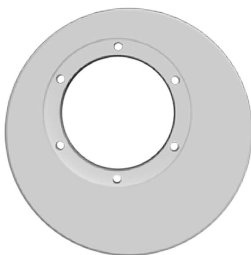

#### **With VTA-Lifter**

To mount the tonearm in combination with VTA-Lifter, you need the tonearm base AC031-8 (Pic.3).

**Pic. 3:** Tonearm base for Performance DC & Ovation (Art. No. AC031-8)



## 2.2 Mounting the tonearm base on a Clearaudio Innovation series turntable

Please check that the correct tonearm base is mounted on your turntable (Pic. 4).

Please note that you will need a different tonearm base, if you want to mount the *Universal* tonearm in combination with the VTA-Lifter (Pic. 6).

If the tonearm base is already pre-assembled, it is in a position which is optimized for the packaging. The position of the tonearm base will be correct during the adjustment of the tonearm.

If not, remove the previous tonearm base by loosening the screw of the aluminium base with a 7mm hex wrench.

Exchange the tonearm base against the correct one and place it as seen in picture 6.

Now you can loosely tighten it so that the tonearm base is still rotatable.



### **Without VTA-Lifter**

To mount the tonearm without VTA-Lifter, you need the tonearm base AC030-4 (Pic. 4).

**Pic. 4:** Tonarme base for Innovation Serie (Art. No. AC030-4)



### **With VTA-Lifter**

To mount the tonearm in combination with VTA-Lifter, you need the tonearm base AC030-10 (Pic. 5).

**Pic. 5:** Tonarme base for Innovation Serie (Art. No. AC030-10)

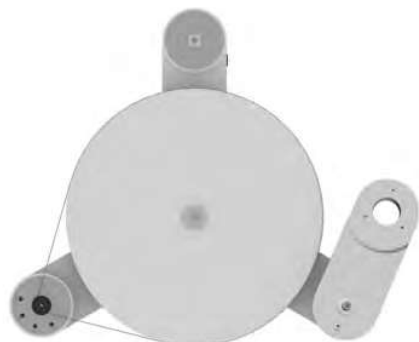

**Pic. 6:** Rough alignment of the tonearm base

## 2.3 Mounting the clamping ring on a other manufacturers' turntables

Drill three holes into the turntable chassis to mount the aluminium clamping ring.

Use the measurements given in the drawing template below to ensure the correct position of the three holes (Pic. 7).

Use a 3.3mm drill for this step. After you have drilled the three holes, thread the holes using an appropriate tap cutter. If the material of the turntable chassis is not suitable for threading, please use a 4.5mm drill for the holes. In this case, you will need longer screws with nuts to fit the tonearm base.

**Please note that this image is not true to scale.**

**Please note:**

**This drilling template is only suitable for *Universal* 9 inch tonearms.**

**Please see the technical details on page 18 for the correct distance between platter spindle and tonearm pivot point of the *Universal* 12 inch tonearm.**

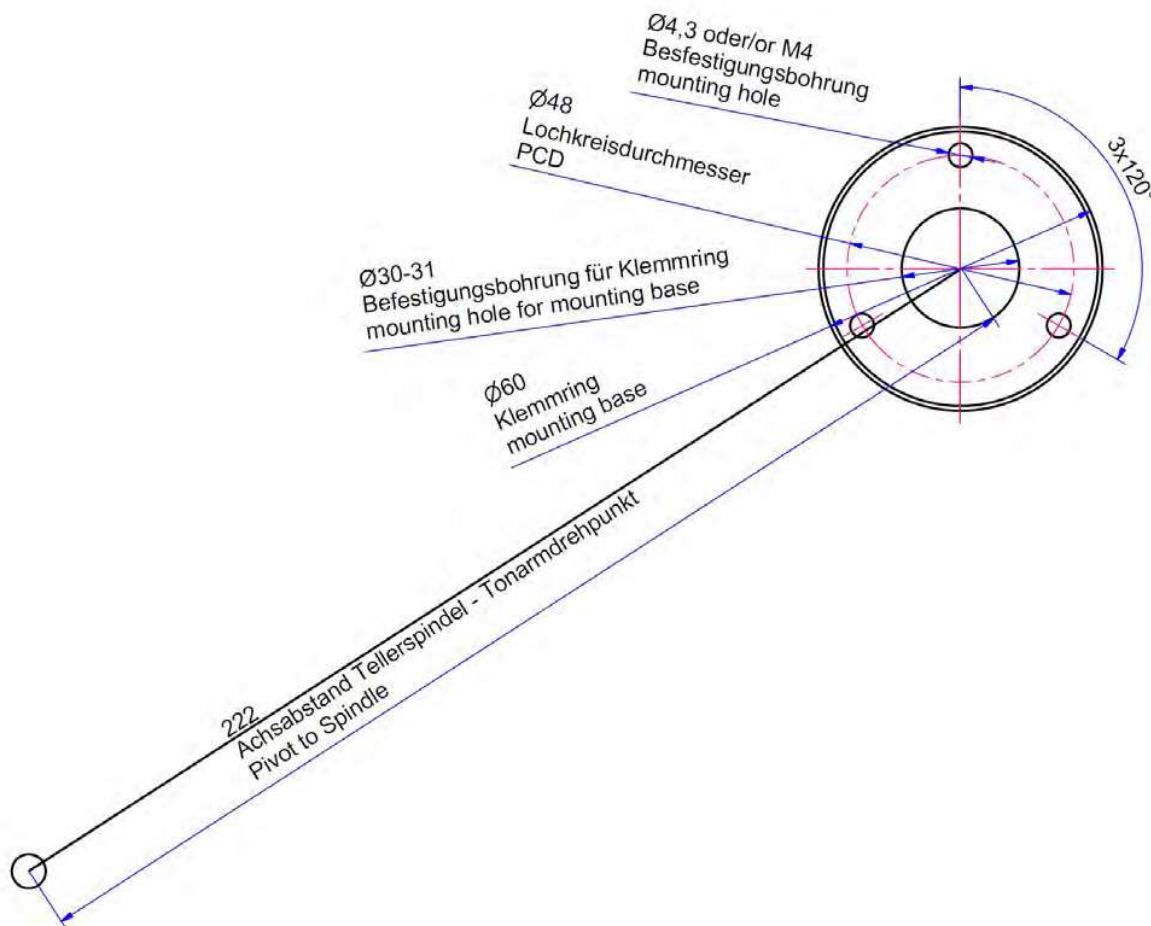

**Pic. 7:** Drilling template for mounting the tonearm base on a other manufacturers' turntable

## 2.4 Mounting the VTA-Lifter on a other manufacturers' turntables

In order to mount the VTA-Lifter on the turntable chassis, please first drill the holes into the turntable chassis.

To ensure the correct position of the holes, please use the measurements given in the drawing template below (Pic. 8).

**Please note that this image is not true to scale.**

**Please note:**

**This drilling template is only suitable for *Universal* 9 inch tonearms.**

**Please see the technical details on page 18 for the correct distance between platter spindle and tonearm pivot point of the *Universal* 12 inch tonearm.**

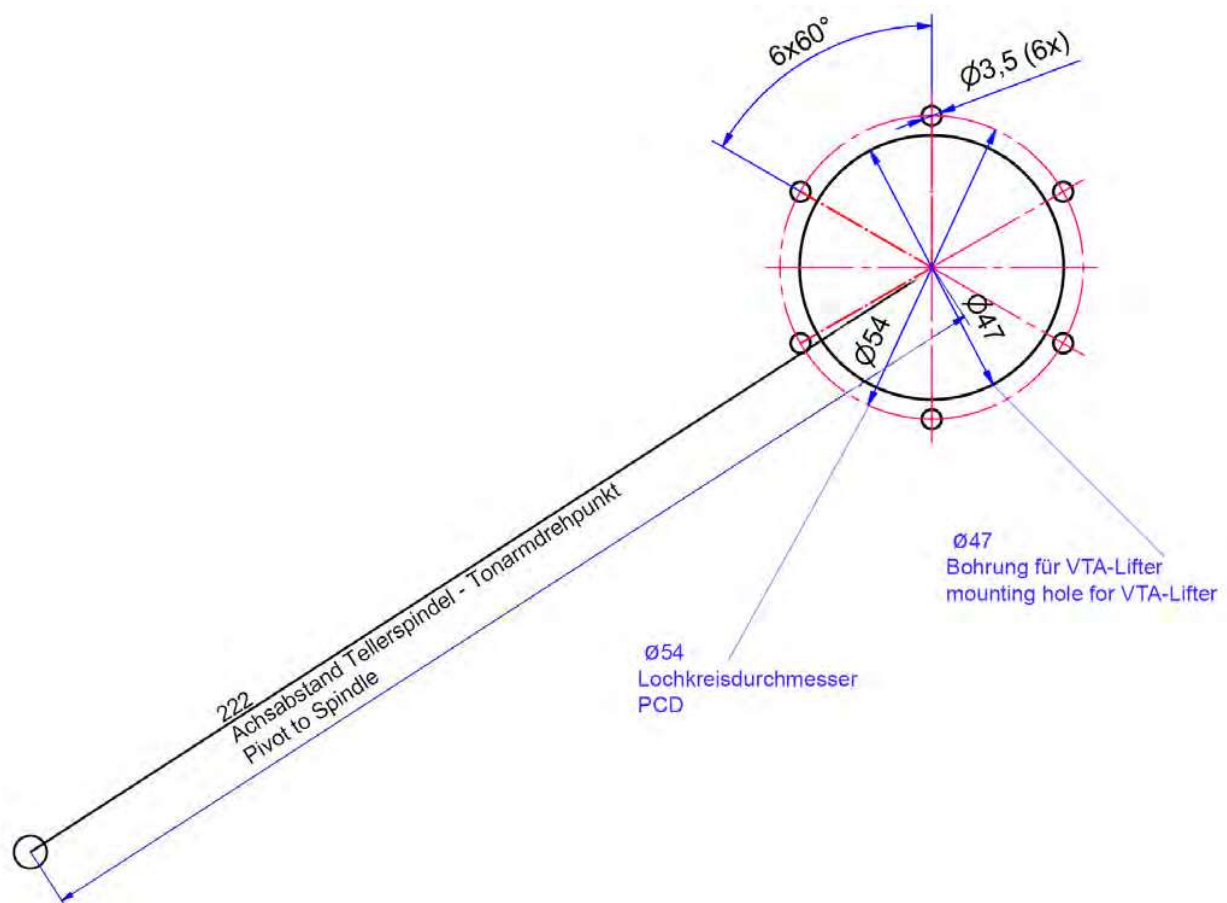

**Pic. 8:** Drilling template for mounting the VTA-Lifter on a other manufacturers' turntable

### 3. Mounting the *Universal* tonearm without VTA-Lifter



**Pic. 9:** Mounting the clamping ring without VTA-Lifter

To assemble the *Universal* tonearm with VTA-Lifter, please follow the separate user manual for the VTA-Lifter.

Now you can attach the clamping ring to the tonearm base with the 3 supplied M4 x 10 screws.

Make sure that the side hole of the clamping ring remains accessible (see Pic. 9).

First insert the tonearm cable and then the tonearm foot of the *Universal* tonearm into the hole of the clamping ring (Pic. 5).

Now fix the tonearm with the screws and the hex wrench. Do not over-tighten for later adjustments.

### 4. Adjustment of the distance between spindle and pivot point

We recommend to use the **Clearaudio** alignment gauge (Art. No. AC005/IEC, also available from [www.analogshop.de](http://www.analogshop.de)) for the exact setting of the tonearm pivot point.

Make sure that the distance between spindle and the pivot point of the tonearm is exactly 222mm (for *Universal*/9 inch) and 295mm (for *Universal*/12 inch) (Pic. 10). You can adjust the distance by rotating the tonearm base.

Please tighten the tonearm base and check the measurement again.

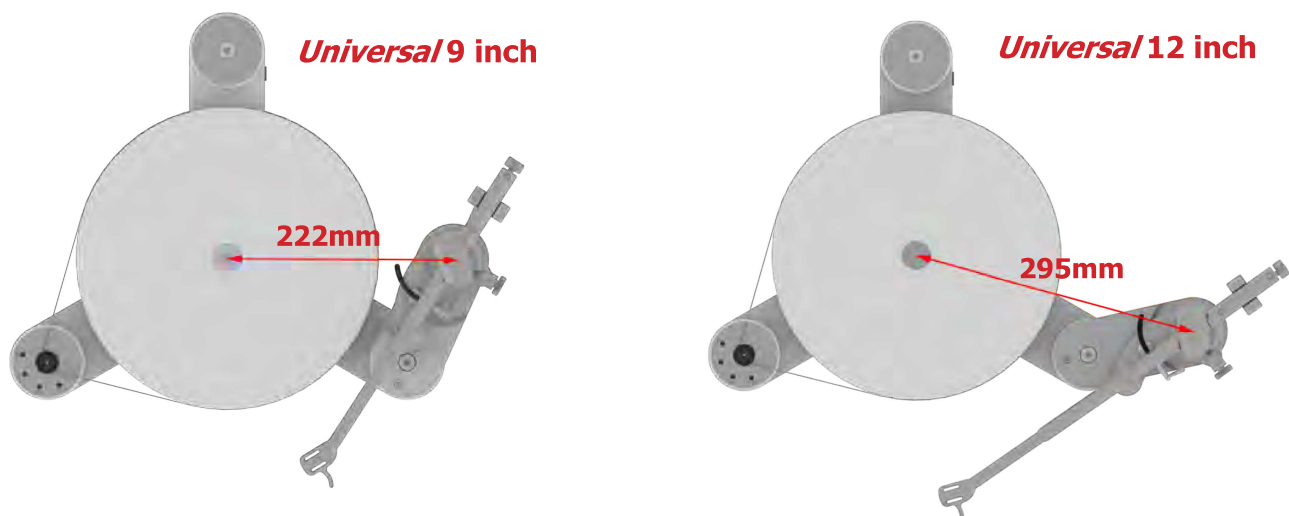

**Pic. 10:** Distance between spindle and tonearm pivot point

## 5. Adjustment of the *Universal* tonearm

The following settings require to mount the cartridge on the headshell.  
Always follow the cartridge manufacturer's instructions.

**Leave the stylus protector on your cartridge to avoid any damages!**

Now you can connect the respective signal cable with the matching color pins of the cartridge.  
Please note the following colour coding:

**Red:** right channel / R+  
**Green:** right channel / R-  
**White:** left channel / L+  
**Blue:** left channel / L-

Connect the pins of your cartridge to the jacks of the headshell or tonearm cable, taking care not to use too much force.  
Use suitable precision pliers or tweezers for assistance if necessary.

### 5.1 Adjustment of the VTA



**Pic. 11:** Adjustment of the VTA

The tonearm remains loose in the clamping ring and is not screwed tight.

Now place a record or the **Clearaudio** alignment gauge (Art. No. AC005/IEC) on the turntable and remove the stylus protector from your cartridge.

Remove the antiskating screw of the tonearm, this screw will be re-inserted later.

**Make sure that the tracking force is roughly adjusted in order not to damage the cartridge.**

**Please be extremely careful during the following steps!**  
**Never move the cartridge in the alignment gauge while it is lowered.**

Place the included Mini Level Gauge on the headshell and take the tonearm from its resting position so that it rests on the lowered lift bracket.

Lift the entire tonearm in the clamping ring so that the cartridge hovers over the platter.

Now carefully lower the entire tonearm in the clamping ring so that the tonearm tube is parallel to the platter. The tonearm tube should not touch the lift bracket, but the needle must rest on the record or the alignment gauge.

While the tonearm is in this position you can hand-tight the clamping ring.  
After fixing, you can re-check the setting using the Mini Level Gauge and correct if necessary.

If the position is still correct, you can put the tonearm back in the rest position holder and put the stylus protector back on.

### 5.2 Alignment of the tonearm

We recommend to use a ruler or the **Clearaudio** alignment gauge (Art. No. AC005/IEC) for the correct alignment of the *Universal* tonearm.

Open the clamping ring again, being careful as the height of the tonearm is already adjusted.

Set the distance as following (Pic. 12):

- *Universal* 9 inch

Distance from platter to rest position holder	= 195mm ( $\pm$ 3mm)
Distance from platter to headshell center	= 217mm ( $\pm$ 3mm)

- *Universal* 12 inch

Distance from platter to rest position holder	= 251mm ( $\pm$ 3mm)
Distance from platter to headshell center	= 248mm ( $\pm$ 3mm)

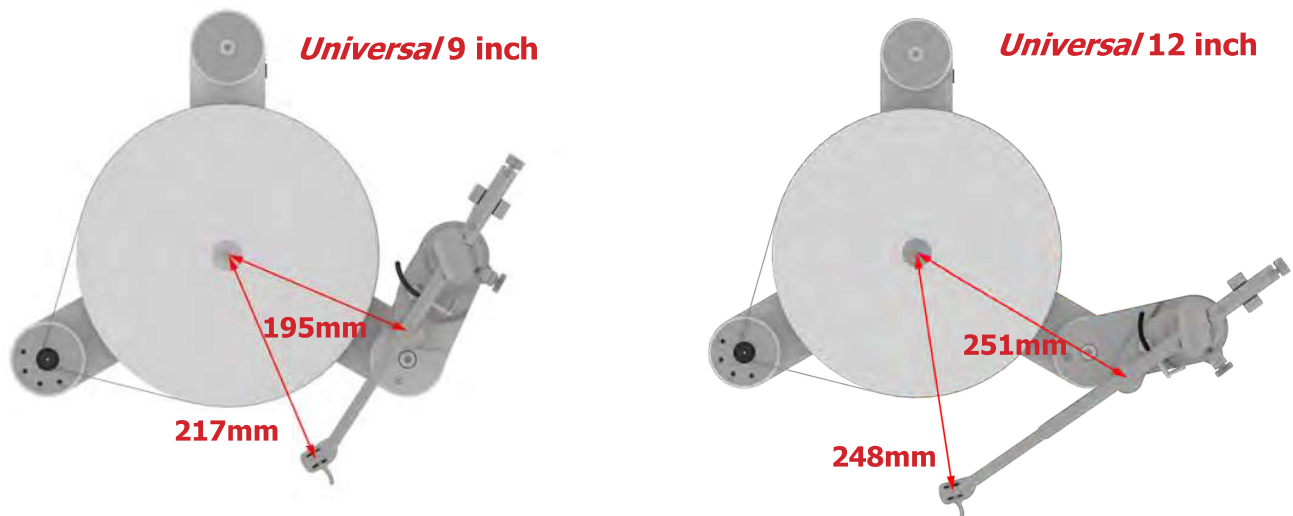

**Pic. 12:** Alignment of the tonearm

Fix the tonearm in the clamping ring and re-check the previous settings again as described and correct them if necessary.



### 5.3 Alignment and adjustment of the cartridge

Use the adjustment template, included in the scope of the delivery for the final tonearm and cartridge adjustment. Place it directly on the turntable (without record) and align it with the arrow pointing toward the tonearm pivot point (Pic. 13).

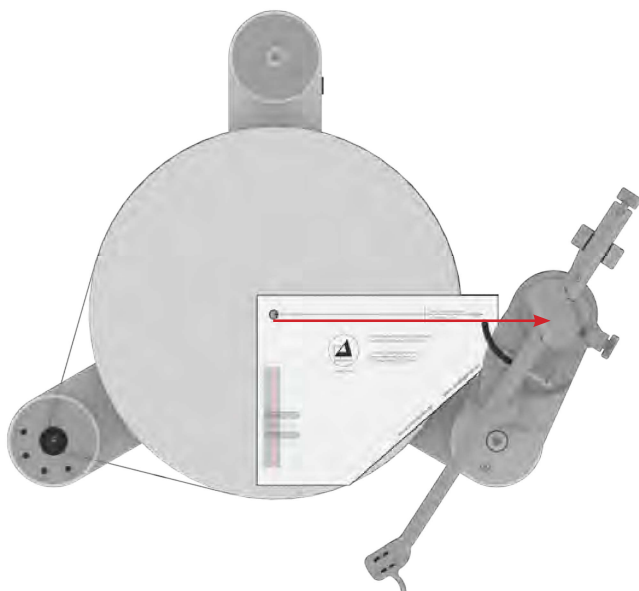

**Pic. 13:** Placing the adjustment template

Take the tonearm out of the rest position and align it in the area of the cross lines. Lower the tonearm and check the alignment.



The cartridge body must be aligned in the template grid and the needle tip should be located in the cross lines.

Also, the side and front edges of the housing have to be parallel to the grid lines.

To correct the adjustment, loosen the screws of the cartridge to move the cartridge in the headshell.

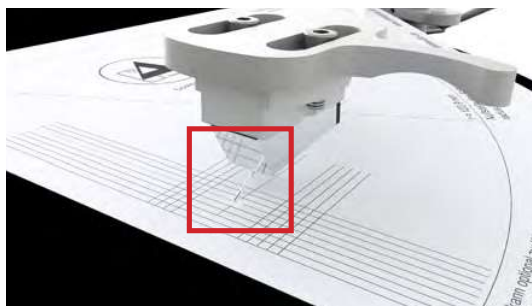

Re-check the setting again after you have tightened the screws.

**Pic. 14:** Alignment of the cartridge

### 5.4 Adjustment of the tracking force

Turn the adjustment screw at the end of the tonearm to increase or lower the tracking force.

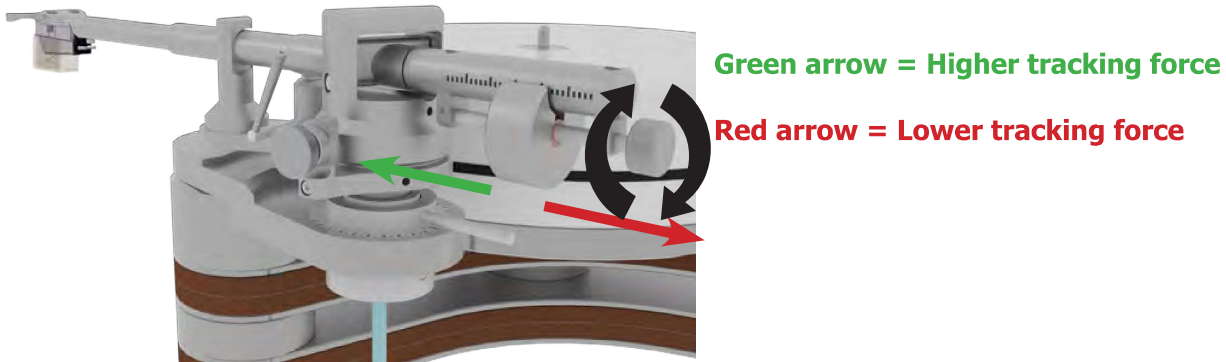

**Pic. 15:** Adjustment of the tracking force

Use the chart below to check whether the correct weight is installed for your cartridge. Please follow the instructions of the respective cartridge manufacturer.

If an exchange is necessary, you can loosen the screw on the underside of the counterweight using an hex wrench (#1.5).

#### Classification of the counterweights for different cartridges, with a recommended tracking force of 2.8g for *Universal 9*":

Counterweight in g	Cartidge weight	
	From...	to....
18.3g	2.9g	5.3g
31.5g	5.1g	8.9g
49.0g <b>(pre-mounted)</b>	7.7g	14.9g
66.0g	11.2g	19.9g
85.0g	15.0g	24.8g

#### Classification of the counterweights for different cartridges, with a recommended tracking force of 2.8g for *Universal 12*":

Counterweight in g	Cartidge weight	
	From...	to....
49.0g	2.9g	11.3g
66.0g <b>(pre-mounted)</b>	5.6g	16.2g
85.0g	8.5g	21.0g

We recommend using the **Clearaudio** „Weight Watcher touch“ digital cartridge scale (Art. No. AC163, also available at [www.analogshop.de](http://www.analogshop.de)) for the correct setting.



## 5.5 Adjustment of the azimuth

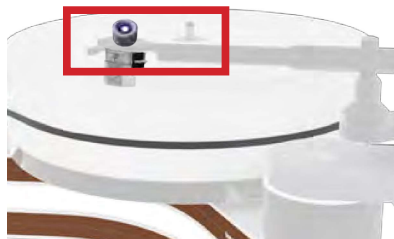

**Pic. 16:** Azimuth adjustment

The azimuth is the angle of the cartridge stylus to the record surface. Viewed from the front, the cartridge needle have to be vertical to the record.

**Please note:**  
**The azimuth is already set at the factory.**

If you still want to optimize the azimuth, place the supplied Mini Level Gauge on the headshell and lower the cartridge onto the record surface.



**Pic. 17:** Screw for azimuth adjustment

To change the azimuth, please proceed as following:  
Loosen the screw (hex wrench #2) on the bottom side of the tonearm tube near the headshell.

Now you can adjust the azimuth by turning the headshell in the tonearm tube.

After you have found the correct position, carefully tighten the small hex screw again without changing the previously selected position.

### 5.6 Adjustment of the antiskating

In order to proceed the next adjustment, the previously removed antiskating screw needs to be re-inserted.

Now you can adjust the antiskating by adjusting the screw (red box Pic. 18). This adjustment depends on the tracking force of your cartridge:

Adjustment of the antiskating:	tracking force	Position of the antiskating screw
Minimal antiskating >	1.0 - 1.5g >	see picture 1
Middle antiskating >	1.5 - 2.0g >	see picture 2
Maximum antiskating >	2.0g and higher >	see picture 3

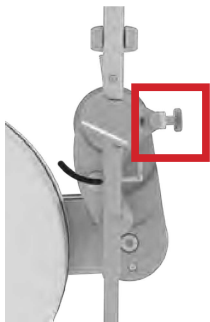

Picture 1  
(minimal antiskating)

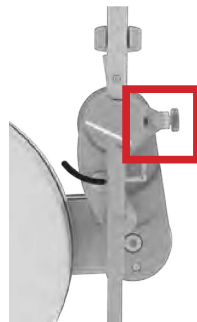

Picture 2  
(Middle antiskating)

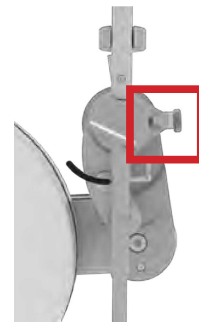

Picture 3  
(maximum antiskating)  
(Screw completely inserted)

**Pic. 18:** Antiskating adjustment

### The tonearm adjustment is now complete.

We recommend to re-check all settings again and correct them if necessary before connecting the tonearm to your phono pre-amplifier.

We hope you enjoy your new *Universal* tonearm.  
Your **Clearaudio** team



## 6. Troubleshooting

First check the possible causes to rule out incorrect operation if you have a problem with your *Universal* tonearm.

Please contact your dealer if the error persists!

**Never try to open the unit and/or repair it yourself, this will void the warranty!**

Error	Cause	Measure
<b>Needle bounces or slides across record</b>	Is the record or the stylus dirty or damaged?	Clean the record / or the cartridge. <b>Clearaudio</b> offers many helpful accessories for care and cleaning. In the event of damage, we recommend an assessment by a specialist and, if necessary, an exchange.
	Has the tracking force been set too high?	Adjust the tracking force. Use only a suitable gauge! For example <b>Clearaudio</b> „Weight Watcher touch“ or „Smart Stylus Gauge“.
	Is the record deformed or scratched?	Use a record clamp or replace the record.
	Is the turntable leveled?	Check the alignment of the turntable and adjust if necessary.
<b>Tonearm lift does not lower or lowers very slowly</b>	The tonearm has not been used for a long time, which means that the grease in the tonearm lift can harden and lower with difficulty.	Operate the lift about 4-5 times to loosen the grease in the tonearm lift and the lift bar will lower evenly again.

## 7. Technical data

<b>Construction details:</b>	Radial tonearm Using ultra low friction bearings Available in 9 and 12 inches
<b>Material:</b>	Aluminium (black/silver), stainless steel, carbon tonearm tube (black/silver)
<b>Cartridge balance range:</b>	9 inch: 2.9g - 24.8g 12 inch: 2.9g - 21.0g
<b>Overhang:</b>	9 inch: 17.00mm 12 inch: 13.01mm
<b>Total length:</b>	9 inch: 345.00mm 12 inch: 420.00mm
<b>Effective length:</b>	9 inch: 239.00mm 12 inch: 308.01mm
<b>Mounting distance (tonearm pivot to spindle):</b>	9 inch: 222.00mm 12 inch: 295.00mm
<b>Offset angle:</b>	9 inch: 24.89° 12 inch: 18.85°
<b>Wiring:</b>	1.1m <b>Clearaudio</b> Super Sixstream terminated with RCA
<b>Weight:</b>	9 inch: approx. 745g (incl. counterweight) 12 inch: approx. 760g (incl. counterweight)
<b>Manufacturer's warranty:</b>	5 years*

\* Provided that the warranty card is correctly completed and returned to **Clearaudio**, or your product is registered online at <https://clearaudio.de/en/service/registration.php>, within 14 days of purchase.